

仕 様 書

カトウ全油圧式オールテレーンクレーン

K A - 3 0 0 0

キャリア：日産ディーゼルK L - A L 6 3 2 Y N

クレーン部主要諸元

1. 名称	300ton吊りオールテレーンクレーン		
2. 型式	KA-3000		
3. クレーン性能			
最大定格総荷重			
・メインブーム	13.6m ブーム	300.0t ×	2.5m
	18.15mブーム	120.0t ×	6.0m
	22.7m ブーム	120.0t ×	6.0m
	31.8m ブーム	70.0t ×	11.0m
	40.9m ブーム	60.0t ×	12.0m
	45.5m ブーム	47.0t ×	14.0m
	50.0m ブーム	35.0t ×	18.0m
	最大作業半径時	8.9t ×	46.0m
・スーパーラフィングジブ	10.0m SL	24.0t ×	22.0m
	15.0m SL	12.0t ×	36.0m
	19.0m SL	12.0t ×	32.0m
	23.0m SL	12.0t ×	26.0m
	27.0m SL	12.0t ×	22.0m
	31.0m SL	9.0t ×	28.0m
	最大作業半径時	1.8t ×	66.0m
・ヘビーリフトジブ	13.0m HL	84.0t ×	9.0m
	22.0m HL	54.0t ×	14.0m
	31.0m HL	35.0t ×	14.0m
	40.0m HL	12.0t ×	48.0m
	47.0m HL	12.0t ×	46.0m
	54.0m HL	9.3t ×	28.0m
	最大作業半径時	1.7t ×	85.0m
最大地上揚程	ブーム	51.0m	
	スーパーラフィングジブ	83.1m	
	ヘビーリフトジブ	106.9m	
巻上ロープ速度	主巻(3層) 高速: 135m/min 低速: 80m/min		
	補巻(3層) 高速: 135m/min 低速: 80m/min		
ブーム上げ速度	100sec/- 1.5° ~ 83°		
ブーム伸長速度	220sec/36.4m		
旋回速度	高速: 1.4min ⁻¹ 低速: 0.7min ⁻¹		

4. 上部旋回体の装置及び構造

メインブーム	箱型5段油圧伸縮式 13.6m～50.0m
スーパーラフィングジブ	2.0mベースブラケット+箱型4段油圧伸縮式 10.0m～31.0m オフセット：5°～60°
ヘビーリフトジブ	4.4mベースブラケット+トラス式 13.0m～54.0m オフセット：10°～60°
巻上装置	油圧モータ駆動、減速機一体型（ディスクブレーキ内蔵） シングルウインチ2基
旋回装置	油圧モータ駆動、減速機一体型（ネガティブブレーキ内蔵） フリー・ロック切換式
旋回後端半径	4,438mm
ロープ（主巻） （補巻）	φ24×370m φ24×370m
カウンタウエイト	80t・60t・40t・25t・10t

5. クレーン用エンジン

名称	三菱 6D24-TE1（国土交通省排出ガス規制適合）
型式	水冷4サイクル直列6気筒 直接噴射式ディーゼルエンジン ターボ付
総排気量	11.94L
最大出力	188kW（255PS）/1,800 min^{-1}
最大トルク	1,079 $\text{N}\cdot\text{m}$ （110 $\text{kgf}\cdot\text{m}$ ）/1,400 min^{-1}
燃料タンク容量	300L
電気システム	24V
バッテリー	115F51×2

6. 油圧装置

オイルポンプ	2連斜軸型バリアブルピストンポンプ+斜板型バリアブルピストンポンプ+2連ギヤポンプ
オイルモータ	巻上用 斜板型2速ピストンモータ 旋回用 斜板型ピストンモータ
コントロールバルブ	マルチプル自動復元式（圧力補償付流量調整弁付）

キャリヤ部主要諸元

1. 車名及び型式	ニッサンディーゼル KL-A L 6 3 2 Y N		
2. 走行性能(台車のみ)			
最高速度	6 0 k m / h		
登坂能力	0. 4 (tanθ)		
最小回転半径	1 1. 6 m		
3. 寸法・重量(台車のみ)			
全 長	1 4, 8 5 0 mm		
全 幅	3, 0 0 0 mm		
全 高	2, 8 7 0 mm		
軸 距	2, 7 7 0+1, 9 5 0+1, 6 5 0+1, 7 0 0+1, 6 5 0 = 9, 7 2 0 mm		
輪 距	前輪 2, 5 1 0 mm 後輪 2, 5 1 0 mm		
乗車定員	2 人		
車両総重量	4 2, 5 1 0 kg		
4. エンジン			
名 称	ニッサンディーゼル RH 1 0		
型 式	水冷4サイクルV型10気筒 電子制御ディーゼルエンジン		
総排気量	2 6. 5 0 7 L		
最大出力	3 8 2 kW (5 2 0 P S) / 2, 2 0 0 m i n ⁻¹		
最大トルク	1, 8 1 4 N・m (1 8 5 kgf・m) / 1, 2 0 0 m i n ⁻¹		
燃料タンク容量	3 0 0 L		
電気システム	2 4 V		
バッテリー	1 1 5 F 5 1 × 2		
5. タイヤ (前輪)	4 4 5 / 9 5 R 2 5	1 7 7 E	ROAD (9 0 0 k P a (9 b a r))
(後輪)	4 4 5 / 9 5 R 2 5	1 7 7 E	ROAD (9 0 0 k P a (9 b a r))

6. 下部走行体の装置及び構造

旋回サークル

ローラーベアリング式、Cリング上下分割式

アウトリガ装置

形式 油圧垂直支持式（サイドサポート併用）

張出幅 9,400 mm（最大張出）

8,400 mm（中間張出）

7,400 mm（中間張出）

6,400 mm（中間張出）

5,400 mm（中間張出）

【注意】

1. 本機は公道走行をする場合、旋回体およびブームを別送し台車のみで走行しなければなりません。
2. 道路法による基本通行条件のC条件適合車です。
3. 道路を通行する場合には、道路法により通行の許可と道路運送車両法による保安基準の緩和が必要です。
4. 構内を移動する時に限り、構内走行姿勢図のような状態で移動できます。
ただし、走行速度は25 km/h以下で走行して下さい。
5. クレーンの旋回体にカウンタウエイトを装着しているときは、必ずアウトリガを使用した状態にして下さい。

AA性能

C/W 80t O/R 7.4m

メインブーム(重荷重装置付)

作業半径	13.6mブーム						
2.5	*300.0						
3.0	230.0						
3.5	210.0						
4.0	190.0						
4.5	175.0						
5.0	162.0						
6.0							
7.0							
8.0							
9.0							
10.0							
11.0							
12.0							
14.0							
16.0							
18.0							
20.0							
掛数	28						
危険角度(°)	-						
フック種類	300t						
フック質量(t)	3.72						

注) *印性能は後方のみ
他は全周同一性能

A1性能

C/W 80t O/R 9.4m

メインブーム(通常伸縮)

作業半径	13.6mブーム	18.15mブーム	22.7mブーム	31.8mブーム	40.9mブーム	45.5mブーム	50.0mブーム
3.0	150.0						
3.5	150.0	120.0					
4.0	150.0	120.0	120.0				
4.5	150.0	120.0	120.0				
5.0	150.0	120.0	120.0	70.0			
6.0	136.9	120.0	120.0	70.0			
7.0	119.4	118.0	117.0	70.0	60.0		
8.0	105.4	104.1	103.0	70.0	60.0	47.0	35.0
9.0	94.1	92.7	91.7	70.0	60.0	47.0	35.0
10.0	84.8	83.3	82.3	70.0	60.0	47.0	35.0
11.0	76.9	75.4	74.4	70.0	60.0	47.0	35.0
12.0		68.7	67.6	65.8	60.0	47.0	35.0
14.0		57.7	56.5	56.6	52.1	47.0	35.0
16.0		41.6	47.2	49.5	45.4	42.9	35.0
18.0			40.0	42.2	40.0	38.2	35.0
20.0			34.3	36.4	35.7	34.2	31.4
22.0				31.7	32.0	30.8	28.3
24.0				27.8	28.8	27.8	25.7
26.0				24.4	25.4	25.2	23.4
28.0				21.6	22.6	22.9	21.5
30.0					20.1	20.4	19.8
32.0					18.0	18.2	18.3
34.0					16.1	16.3	16.8
36.0					14.5	14.7	15.1
38.0					12.3	13.2	13.6
40.0						11.9	12.2
42.0						10.7	11.0
44.0							9.9
46.0							8.9
掛数	14	12	12	7	6	4	4
危険角度(°)	-	-	-	-	-	-	6
フック種類	150t	150t	150t	83t	83t	83t	83t
フック質量(t)	1.86	1.86	1.86	1.0	1.0	1.0	1.0

SA性能

40.9mブーム+2.0m+10.0mSLジブ

オフセット	5°		15°		30°		45°		60°	
作業半径	ブーム角 (°)	荷重 (ton)	ブーム角 (°)	荷重 (ton)	ブーム角 (°)	荷重 (ton)	ブーム角 (°)	荷重 (ton)	ブーム角 (°)	荷重 (ton)
10.0	79.0	24.0								
11.0	78.1	24.0	79.8	24.0						
12.0	77.1	24.0	78.8	24.0						
14.0	75.1	24.0	76.8	24.0	79.1	24.0				
16.0	73.0	24.0	74.7	24.0	77.0	24.0	78.5	21.4	79.6	19.9
18.0	71.0	24.0	72.7	24.0	74.8	23.3	76.2	20.6	77.1	19.4
20.0	68.9	24.0	70.6	24.0	72.6	22.3	73.9	20.0	74.6	19.1
22.0	66.7	24.0	68.4	23.4	70.2	20.7	71.4	19.0	72.1	18.3
24.0	64.5	23.3	66.0	21.6	67.7	19.3	68.9	17.9	69.4	17.4
26.0	62.0	20.8	63.5	20.0	65.2	18.1	66.3	17.0	66.6	16.6
28.0	59.3	17.9	60.9	18.3	62.6	16.9	63.6	16.1	63.7	15.9
30.0	56.6	15.3	58.2	16.0	59.9	15.9	60.8	15.3		
32.0	53.8	13.1	55.3	13.7	57.0	14.3	57.8	14.5		
34.0	50.9	11.2	52.4	11.7	53.9	12.2	54.5	12.5		
36.0	47.7	9.4	49.2	9.9	50.6	10.3	51.0	10.5		
38.0	44.5	7.9	45.9	8.3	47.2	8.6	47.3	8.7		
40.0	41.0	6.5	42.3	6.8	43.4	7.1				
42.0	37.2	5.2	38.5	5.5	39.3	5.7				
44.0	33.1	4.1	34.1	4.3	34.6	4.4				
46.0	28.3	3.0	29.2	3.2						
掛数	2		2		2		2		2	
危険角度(°)	21		21		30		45		60	
フック種類	24t		24t		24t		24t		24t	
フック質量(t)	0.88		0.88		0.88		0.88		0.88	

SA性能

45.5mブーム+2.0m+10.0mSLジブ

オフセット	5°		15°		30°		45°		60°	
	ブーム角 (°)	荷重 (ton)	ブーム角 (°)	荷重 (ton)	ブーム角 (°)	荷重 (ton)	ブーム角 (°)	荷重 (ton)	ブーム角 (°)	荷重 (ton)
11.0	79.4	24.0								
12.0	78.5	24.0								
14.0	76.8	24.0	78.3	24.0						
16.0	75.0	24.0	76.6	24.0	78.6	24.0				
18.0	73.2	24.0	74.8	24.0	76.6	22.1	78.0	19.8	78.8	18.6
20.0	71.4	24.0	72.9	23.4	74.5	20.4	75.8	18.5	76.5	17.5
22.0	69.4	22.2	70.7	20.9	72.4	18.9	73.7	17.3	74.3	16.5
24.0	67.2	19.8	68.6	18.8	70.3	17.5	71.4	16.2	71.9	15.6
26.0	65.0	17.8	66.4	17.0	68.1	16.1	69.1	15.3	69.6	14.8
28.0	62.8	16.1	64.1	15.4	65.7	14.7	66.7	14.2	67.1	14.1
30.0	60.5	14.6	61.8	14.0	63.3	13.4	64.2	13.1	64.5	13.0
32.0	58.1	13.0	59.4	12.8	60.9	12.3	61.7	12.1		
34.0	55.5	11.1	56.9	11.6	58.4	11.3	59.1	11.1		
36.0	52.8	9.3	54.2	9.8	55.7	10.4	56.3	10.3		
38.0	50.0	7.8	51.4	8.2	52.8	8.7	53.3	8.9		
40.0	47.2	6.4	48.5	6.8	49.7	7.2	50.0	7.3		
42.0	44.2	5.1	45.3	5.5	46.4	5.8				
44.0	40.8	4.0	42.1	4.3	43.0	4.5				
46.0	37.4	2.9	38.4	3.2	39.1	3.4				
掛数	2		2		2		2		2	
危険角度(°)	32		32		32		45		60	
フック種類	24t		24t		24t		24t		24t	
フック質量(t)	0.88		0.88		0.88		0.88		0.88	

SA性能

50.0mブーム+2.0m+10.0mSLジブ

オフセット	5°		15°		30°		45°		60°	
	ブーム角 (°)	荷重 (ton)	ブーム角 (°)	荷重 (ton)	ブーム角 (°)	荷重 (ton)	ブーム角 (°)	荷重 (ton)	ブーム角 (°)	荷重 (ton)
12.0	79.5	20.0								
14.0	77.9	20.0	79.4	20.0						
16.0	76.4	20.0	77.8	20.0	79.7	20.0				
18.0	74.7	20.0	76.2	20.0	78.0	20.0	79.4	19.6		
20.0	73.2	20.0	74.6	20.0	76.3	19.6	77.5	18.0	78.2	17.1
22.0	71.6	20.0	72.9	19.5	74.5	17.9	75.6	16.6	76.2	15.9
24.0	69.6	18.4	70.9	17.5	72.5	16.4	73.5	15.3	74.0	14.8
26.0	67.7	16.4	68.9	15.7	70.5	14.9	71.5	14.2	72.0	13.8
28.0	65.6	14.7	66.9	14.2	68.4	13.5	69.4	13.1	69.7	12.9
30.0	63.6	13.3	64.8	12.8	66.3	12.3	67.2	12.0	67.4	11.9
32.0	61.5	11.9	62.7	11.6	64.1	11.2	65.0	11.0	65.1	10.9
34.0	59.3	10.7	60.5	10.5	61.8	10.2	62.7	10.1		
36.0	57.0	9.3	58.2	9.6	59.5	9.3	60.3	9.2		
38.0	54.5	7.7	55.8	8.2	57.2	8.5	57.8	8.5		
40.0	52.1	6.3	53.3	6.7	54.6	7.2	55.1	7.4		
42.0	49.4	5.0	50.6	5.4	51.8	5.8	52.1	6.0		
44.0	46.7	3.9	47.9	4.2	49.0	4.6	49.1	4.7		
46.0	43.7	2.8	44.9	3.1	45.8	3.4				
掛数	2		2		2		2		2	
危険角度(°)	40		40		40		45		60	
フック種類	24t		24t		24t		24t		24t	
フック質量(t)	0.88		0.88		0.88		0.88		0.88	

SA性能

40.9mブーム+2.0m+15.0mSLジブ

オフセット 作業半径	5°		15°		30°		45°		60°	
	ブーム角 (°)	荷重 (ton)	ブーム角 (°)	荷重 (ton)	ブーム角 (°)	荷重 (ton)	ブーム角 (°)	荷重 (ton)	ブーム角 (°)	荷重 (ton)
11.0	79.3	12.0								
12.0	78.3	12.0								
14.0	76.5	12.0	78.9	12.0						
16.0	74.6	12.0	77.0	12.0						
18.0	72.7	12.0	75.1	12.0	78.3	12.0				
20.0	70.8	12.0	73.2	12.0	76.3	12.0	78.8	12.0		
22.0	68.8	12.0	71.2	12.0	74.3	12.0	76.7	12.0	78.2	12.0
24.0	66.8	12.0	69.2	12.0	72.2	12.0	74.4	12.0	75.9	12.0
26.0	64.8	12.0	67.1	12.0	70.0	12.0	72.2	12.0	73.4	12.0
28.0	62.7	12.0	64.9	12.0	67.8	12.0	69.9	12.0	70.9	12.0
30.0	60.6	12.0	62.8	12.0	65.5	12.0	67.4	12.0	68.2	11.9
32.0	58.4	12.0	60.5	12.0	63.2	12.0	64.8	11.7	65.4	11.4
34.0	56.1	12.0	58.2	12.0	60.7	11.8	62.2	11.1	62.5	11.0
36.0	53.6	11.3	55.8	12.0	58.1	11.2	59.4	10.6		
38.0	50.9	9.7	53.0	10.4	55.4	10.6	56.4	10.2		
40.0	48.1	8.3	50.2	8.9	52.4	9.6	53.2	9.8		
42.0	45.0	7.0	47.1	7.5	49.1	8.1	49.6	8.3		
44.0	41.9	5.9	43.8	6.3	45.6	6.8				
46.0	38.4	4.8	40.3	5.2	41.8	5.5				
48.0	34.7	3.8	36.4	4.1	37.6	4.4				
50.0	30.5	2.9	32.0	3.2	32.7	3.3				
52.0	25.6	2.1	26.9	2.2						
54.0	19.3	1.3	19.9	1.4						
掛数	1		1		1		1		1	
危険角度(°)	17		17		30		45		60	
フック種類	12t		12t		12t		12t		12t	
フック質量(t)	0.42		0.42		0.42		0.42		0.42	

SA性能

45.5mブーム+2.0m+15.0mSLジブ

オフセット	5°		15°		30°		45°		60°	
	ブーム角 (°)	荷重 (ton)	ブーム角 (°)	荷重 (ton)	ブーム角 (°)	荷重 (ton)	ブーム角 (°)	荷重 (ton)	ブーム角 (°)	荷重 (ton)
14.0	77.8	12.0								
16.0	76.1	12.0	78.4	12.0						
18.0	74.4	12.0	76.6	12.0						
20.0	72.8	12.0	74.9	12.0	77.8	12.0				
22.0	71.0	12.0	73.2	12.0	76.0	12.0	78.2	12.0		
24.0	69.3	12.0	71.4	12.0	74.2	12.0	76.2	12.0	77.6	12.0
26.0	67.5	12.0	69.5	12.0	72.2	12.0	74.2	12.0	75.4	11.7
28.0	65.6	12.0	67.7	12.0	70.3	12.0	72.2	11.7	73.1	11.2
30.0	63.8	12.0	65.8	12.0	68.4	12.0	70.0	11.1	70.9	10.7
32.0	61.8	12.0	63.8	12.0	66.3	11.3	67.7	10.5	68.4	10.2
34.0	59.8	11.7	61.7	11.2	64.1	10.6	65.5	10.0	65.9	9.7
36.0	57.6	10.7	59.5	10.3	61.7	9.9	63.1	9.5	63.3	9.4
38.0	55.3	9.6	57.2	9.5	59.3	9.1	60.6	9.0		
40.0	52.8	8.1	54.8	8.7	56.9	8.5	57.9	8.3		
42.0	50.2	6.9	52.2	7.4	54.2	7.8	55.1	7.7		
44.0	47.5	5.7	49.4	6.2	51.4	6.8	52.1	7.0		
46.0	44.7	4.6	46.5	5.1	48.3	5.6	48.7	5.7		
48.0	41.7	3.6	43.5	4.0	45.0	4.4				
50.0	38.5	2.7	40.2	3.1	41.6	3.4				
52.0	35.0	1.9	36.6	2.2	37.6	2.4				
54.0			32.6	1.4						
掛数	1		1		1		1		1	
危険角度(°)	29		29		30		45		60	
フック種類	12t		12t		12t		12t		12t	
フック質量(t)	0.42		0.42		0.42		0.42		0.42	

SA性能

50.0mブーム+2.0m+15.0mSLジブ

オフセット	5°		15°		30°		45°		60°	
	ブーム角 (°)	荷重 (ton)	ブーム角 (°)	荷重 (ton)	ブーム角 (°)	荷重 (ton)	ブーム角 (°)	荷重 (ton)	ブーム角 (°)	荷重 (ton)
14.0	78.9	12.0								
16.0	77.4	12.0	79.4	12.0						
18.0	76.0	12.0	78.0	12.0						
20.0	74.5	12.0	76.4	12.0	79.1	12.0				
22.0	72.9	12.0	74.9	12.0	77.5	12.0	79.6	12.0		
24.0	71.3	12.0	73.3	12.0	75.9	12.0	77.8	12.0	79.1	12.0
26.0	69.7	12.0	71.7	12.0	74.2	12.0	76.1	12.0	77.1	11.5
28.0	68.1	12.0	70.0	12.0	72.6	12.0	74.3	11.4	75.2	10.9
30.0	66.5	12.0	68.4	12.0	70.7	11.4	72.3	10.6	73.1	10.2
32.0	64.8	11.8	66.6	11.3	68.7	10.6	70.3	9.9	70.9	9.6
34.0	62.8	10.7	64.6	10.3	66.7	9.8	68.2	9.3	68.7	9.1
36.0	60.9	9.7	62.6	9.4	64.7	9.1	66.0	8.7	66.5	8.6
38.0	58.9	8.8	60.6	8.6	62.6	8.3	63.9	8.2	64.1	8.1
40.0	56.7	8.0	58.5	7.9	60.5	7.6	61.5	7.5		
42.0	54.5	6.7	56.3	7.2	58.2	7.0	59.2	6.9		
44.0	52.1	5.5	53.9	6.1	55.8	6.4	56.7	6.4		
46.0	49.7	4.5	51.4	5.0	53.3	5.6	54.1	5.9		
48.0	47.1	3.5	48.9	4.0	50.6	4.5	51.1	4.7		
50.0	44.5	2.6	46.1	3.0	47.7	3.4				
52.0	41.6	1.8	43.2	2.1	44.6	2.5				
54.0			40.1	1.3	41.2	1.6				
掛数	1		1		1		1		1	
危険角度(°)	38		38		38		45		60	
フック種類	12t		12t		12t		12t		12t	
フック質量(t)	0.42		0.42		0.42		0.42		0.42	

SA性能

40.9mブーム+2.0m+19.0mSLジブ

オフセット	5°		15°		30°		45°		60°	
	ブーム角 (°)	荷重 (ton)	ブーム角 (°)	荷重 (ton)	ブーム角 (°)	荷重 (ton)	ブーム角 (°)	荷重 (ton)	ブーム角 (°)	荷重 (ton)
12.0	79.5	12.0								
14.0	77.8	12.0								
16.0	76.1	12.0	79.0	12.0						
18.0	74.4	12.0	77.3	12.0						
20.0	72.7	12.0	75.5	12.0	79.4	12.0				
22.0	70.9	12.0	73.7	12.0	77.4	12.0				
24.0	69.1	12.0	71.8	12.0	75.5	12.0	78.4	10.4		
26.0	67.2	12.0	69.9	12.0	73.6	11.6	76.2	10.2	78.0	9.1
28.0	65.3	12.0	68.0	12.0	71.5	11.1	74.0	9.9	75.7	9.0
30.0	63.4	12.0	66.0	11.4	69.4	10.7	71.8	9.7	73.2	8.9
32.0	61.3	11.4	63.8	10.9	67.2	10.3	69.5	9.4	70.7	8.8
34.0	59.2	10.7	61.7	10.4	64.9	10.0	67.1	9.2	68.0	8.8
36.0	56.9	10.2	59.5	10.0	62.6	9.6	64.6	9.0	65.3	8.8
38.0	54.7	9.6	57.2	9.6	60.2	9.2	62.0	8.7	62.3	8.6
40.0	52.3	9.1	54.8	9.2	57.6	8.8	59.2	8.4		
42.0	49.6	8.1	52.2	8.8	54.9	8.4	56.2	8.0		
44.0	46.9	6.9	49.5	7.6	52.1	8.0	53.2	7.7		
46.0	44.0	5.9	46.5	6.4	49.0	7.1	49.7	7.3		
48.0	41.0	4.9	43.3	5.4	45.5	5.9				
50.0	37.6	4.0	39.9	4.4	41.8	4.8				
52.0	34.0	3.1	36.1	3.5	37.5	3.8				
54.0	30.0	2.4	31.8	2.6	32.7	2.8				
56.0	25.1	1.6	26.7	1.8						
掛数	1		1		1		1		1	
危険角度(°)	19		19		30		45		60	
フック種類	12t		12t		12t		12t		12t	
フック質量(t)	0.42		0.42		0.42		0.42		0.42	

SA性能

45.5mブーム+2.0m+19.0mSLシブ

オフセット	5°		15°		30°		45°		60°	
	ブーム角 (°)	荷重 (ton)	ブーム角 (°)	荷重 (ton)	ブーム角 (°)	荷重 (ton)	ブーム角 (°)	荷重 (ton)	ブーム角 (°)	荷重 (ton)
14.0	79.0	12.0								
16.0	77.4	12.0								
18.0	75.9	12.0	78.5	12.0						
20.0	74.3	12.0	77.0	12.0						
22.0	72.8	12.0	75.3	12.0	78.9	12.0				
24.0	71.1	12.0	73.7	12.0	77.1	12.0	79.7	10.6		
26.0	69.5	12.0	72.1	12.0	75.4	11.9	77.9	10.3	79.5	9.2
28.0	67.8	12.0	70.3	12.0	73.5	11.2	76.0	10.1	77.4	9.1
30.0	66.1	12.0	68.7	12.0	71.6	10.5	74.0	9.6	75.3	9.0
32.0	64.4	12.0	66.8	11.2	69.6	9.9	71.9	9.1	73.0	8.6
34.0	62.5	11.2	64.8	10.5	67.6	9.3	69.7	8.6	70.7	8.3
36.0	60.4	10.2	62.7	9.8	65.5	8.8	67.5	8.2	68.3	7.9
38.0	58.4	9.4	60.7	9.0	63.4	8.3	65.2	7.8	65.8	7.6
40.0	56.3	8.6	58.5	8.3	61.2	7.9	62.8	7.4	63.2	7.3
42.0	54.0	7.9	56.3	7.7	58.9	7.4	60.4	7.1		
44.0	51.6	6.7	54.0	7.1	56.5	6.9	57.8	6.8		
46.0	49.2	5.6	51.5	6.3	53.9	6.4	55.0	6.3		
48.0	46.5	4.7	48.8	5.2	51.2	5.9	52.1	5.9		
50.0	43.7	3.7	46.0	4.3	48.2	4.8	48.7	5.0		
52.0	40.9	2.9	43.0	3.4	45.0	3.8				
54.0	37.7	2.1	39.8	2.5	41.5	2.9				
56.0	34.4	1.4	36.3	1.7	37.6	2.0				
掛数	1		1		1		1		1	
危険角度(°)	31		31		31		45		60	
フック種類	12t		12t		12t		12t		12t	
フック質量(t)	0.42		0.42		0.42		0.42		0.42	

SA性能

50.0mブーム+2.0m+19.0mSLジブ

オフセット 作業半径	5°		15°		30°		45°		60°	
	ブーム角 (°)	荷重 (ton)	ブーム角 (°)	荷重 (ton)	ブーム角 (°)	荷重 (ton)	ブーム角 (°)	荷重 (ton)	ブーム角 (°)	荷重 (ton)
16.0	78.6	12.0								
18.0	77.2	12.0	79.7	12.0						
20.0	75.8	12.0	78.3	12.0						
22.0	74.4	12.0	76.8	12.0	80.2	12.0				
24.0	73.0	12.0	75.4	12.0	78.6	12.0				
26.0	71.6	12.0	73.9	12.0	77.1	11.9	79.3	10.4		
28.0	70.1	12.0	72.5	12.0	75.3	11.0	77.6	10.0	78.9	9.1
30.0	68.6	12.0	70.8	11.5	73.6	10.2	75.7	9.4	77.0	8.9
32.0	66.9	11.3	69.0	10.6	71.8	9.5	73.8	8.8	75.0	8.4
34.0	65.1	10.3	67.2	9.8	69.9	8.9	71.9	8.3	72.9	7.9
36.0	63.2	9.4	65.4	9.0	68.1	8.3	69.9	7.7	70.8	7.5
38.0	61.4	8.5	63.6	8.3	66.2	7.7	67.9	7.3	68.7	7.1
40.0	59.5	7.8	61.7	7.6	64.2	7.2	65.8	6.8	66.4	6.7
42.0	57.5	7.1	59.6	6.9	62.2	6.7	63.7	6.4	64.0	6.4
44.0	55.5	6.5	57.6	6.3	60.1	6.2	61.4	6.1		
46.0	53.3	5.4	55.5	5.8	57.8	5.7	59.1	5.6		
48.0	51.0	4.4	53.3	5.1	55.5	5.2	56.6	5.2		
50.0	48.6	3.5	50.8	4.1	53.2	4.8	53.9	4.8		
52.0	46.2	2.7	48.3	3.2	50.5	3.8	51.1	4.1		
54.0	43.6	1.9	45.6	2.4	47.6	2.9				
56.0			42.8	1.6	44.6	2.0				
掛数	1		1		1		1		1	
危険角度(°)	39		39		39		45		60	
フック種類	12t		12t		12t		12t		12t	
フック質量(t)	0.42		0.42		0.42		0.42		0.42	

SA性能

40.9mブーム+2.0m+23.0mSLジブ

オフセット	5°		15°		30°		45°		60°	
	ブーム角 (°)	荷重 (ton)	ブーム角 (°)	荷重 (ton)	ブーム角 (°)	荷重 (ton)	ブーム角 (°)	荷重 (ton)	ブーム角 (°)	荷重 (ton)
14.0	79.1	12.0								
16.0	77.5	12.0								
18.0	75.9	12.0	79.2	12.0						
20.0	74.3	12.0	77.6	12.0						
22.0	72.7	12.0	76.0	12.0	80.2	10.4				
24.0	71.0	12.0	74.2	11.5	78.4	10.1				
26.0	69.3	11.9	72.4	10.9	76.5	9.8	79.9	8.1		
28.0	67.5	11.1	70.5	10.3	74.6	9.4	77.8	7.8		
30.0	65.6	10.4	68.6	9.8	72.6	9.0	75.7	7.6	77.9	6.8
32.0	63.7	9.8	66.7	9.3	70.6	8.7	73.6	7.5	75.5	6.7
34.0	61.7	9.2	64.7	8.8	68.6	8.4	71.4	7.3	73.1	6.7
36.0	59.7	8.7	62.7	8.4	66.5	8.1	69.2	7.1	70.5	6.6
38.0	57.6	8.2	60.6	8.1	64.3	7.8	66.8	7.0	67.9	6.6
40.0	55.5	7.8	58.5	7.7	62.0	7.5	64.3	6.9	65.1	6.5
42.0	53.3	7.4	56.2	7.4	59.7	7.3	61.8	6.8	62.2	6.5
44.0	51.0	7.0	53.9	7.1	57.3	7.1	59.1	6.7		
46.0	48.6	6.7	51.5	6.9	54.6	6.8	56.2	6.5		
48.0	45.9	5.8	48.9	6.5	51.9	6.5	53.0	6.3		
50.0	43.1	4.9	46.0	5.5	48.9	6.2	49.6	6.1		
52.0	40.2	4.1	42.9	4.6	45.5	5.2				
54.0	36.9	3.3	39.5	3.7	41.8	4.2				
56.0	33.4	2.6	35.9	2.9	37.6	3.3				
58.0	29.4	1.9	31.7	2.2	32.7	2.4				
60.0	24.9	1.3	26.7	1.5						
掛数	1		1		1		1		1	
危険角度(°)	21		21		30		45		60	
フック種類	12t		12t		12t		12t		12t	
フック質量(t)	0.42		0.42		0.42		0.42		0.42	

SA性能

45.5mブーム+2.0m+23.0mSLジブ

オフセット 作業半径	5°		15°		30°		45°		60°	
	ブーム角 (°)	荷重 (ton)	ブーム角 (°)	荷重 (ton)	ブーム角 (°)	荷重 (ton)	ブーム角 (°)	荷重 (ton)	ブーム角 (°)	荷重 (ton)
16.0	78.7	12.0								
18.0	77.2	12.0								
20.0	75.8	12.0	78.9	12.0						
22.0	74.3	12.0	77.4	12.0						
24.0	72.9	12.0	75.9	12.0	79.7	10.2				
26.0	71.4	12.0	74.2	11.3	78.0	9.9				
28.0	69.8	11.8	72.5	10.7	76.3	9.6	79.2	7.9		
30.0	68.1	11.1	70.9	10.2	74.6	9.3	77.4	7.7	79.3	6.9
32.0	66.4	10.4	69.2	9.7	72.7	8.9	75.5	7.6	77.2	6.8
34.0	64.6	9.8	67.4	9.3	70.9	8.4	73.5	7.4	75.1	6.7
36.0	62.9	9.3	65.6	8.9	69.0	7.9	71.6	7.2	72.9	6.6
38.0	61.0	8.8	63.8	8.4	67.0	7.5	69.5	6.9	70.6	6.6
40.0	59.1	8.3	61.7	7.8	65.0	7.1	67.3	6.6	68.3	6.3
42.0	57.1	7.6	59.8	7.4	63.0	6.7	65.0	6.3	65.7	6.1
44.0	55.1	7.0	57.7	6.8	60.7	6.3	62.7	6.0	63.1	5.9
46.0	52.9	6.5	55.5	6.3	58.5	6.0	60.2	5.7		
48.0	50.6	5.5	53.2	5.8	56.2	5.7	57.7	5.5		
50.0	48.2	4.6	50.9	5.3	53.7	5.3	54.9	5.2		
52.0	45.6	3.8	48.3	4.4	51.0	4.9	52.0	4.9		
54.0	42.9	3.0	45.6	3.6	48.2	4.2	48.7	4.4		
56.0	40.2	2.3	42.7	2.8	44.9	3.3				
58.0	37.1	1.6	39.5	2.1	41.5	2.5				
60.0			36.1	1.4	37.6	1.7				
掛数	1		1		1		1		1	
危険角度(°)	33		33		33		45		60	
フック種類	12t		12t		12t		12t		12t	
フック質量(t)	0.42		0.42		0.42		0.42		0.42	

SA性能

50.0mブーム+2.0m+23.0mSLジブ

オフセット	5°		15°		30°		45°		60°	
作業半径	ブーム角	荷重	ブーム角	荷重	ブーム角	荷重	ブーム角	荷重	ブーム角	荷重
	(°)	(ton)	(°)	(ton)	(°)	(ton)	(°)	(ton)	(°)	(ton)
16.0	79.6	11.0								
18.0	78.3	11.0								
20.0	77.0	11.0	79.8	11.0						
22.0	75.7	11.0	78.5	11.0						
24.0	74.4	11.0	77.2	11.0						
26.0	73.0	11.0	75.8	11.0	79.3	10.1				
28.0	71.7	11.0	74.4	11.0	77.8	9.8				
30.0	70.3	11.0	72.9	10.6	76.3	9.4	78.8	7.8		
32.0	68.8	10.9	71.3	9.8	74.6	8.7	77.1	7.7	78.7	6.8
34.0	67.2	10.0	69.7	9.1	72.9	8.1	75.4	7.5	76.9	6.7
36.0	65.5	9.1	67.9	8.4	71.1	7.6	73.5	7.0	74.9	6.7
38.0	63.7	8.3	66.2	7.8	69.4	7.1	71.6	6.6	72.8	6.4
40.0	62.0	7.6	64.4	7.2	67.5	6.6	69.7	6.2	70.7	6.0
42.0	60.1	6.9	62.7	6.7	65.6	6.2	67.7	5.8	68.5	5.7
44.0	58.3	6.3	60.8	6.2	63.7	5.8	65.7	5.5	66.3	5.4
46.0	56.5	5.8	58.8	5.7	61.7	5.4	63.5	5.2	63.9	5.1
48.0	54.4	5.3	56.9	5.2	59.7	5.1	61.3	4.9		
50.0	52.3	4.4	54.9	4.8	57.6	4.7	59.0	4.6		
52.0	50.1	3.6	52.7	4.2	55.3	4.3	56.6	4.3		
54.0	47.8	2.8	50.3	3.4	53.0	4.0	53.9	4.0		
56.0	45.3	2.1	47.8	2.6	50.3	3.3	51.1	3.6		
58.0	42.8	1.4	45.2	1.9	47.5	2.4				
60.0					44.6	1.7				
掛数	1		1		1		1		1	
危険角度(°)	40		41		41		45		60	
フック種類	12t		12t		12t		12t		12t	
フック質量(t)	0.42		0.42		0.42		0.42		0.42	

SA性能

40.9mブーム+2.0m+27.0mSLジブ

オフセット 作業半径	5°		15°		30°		45°		60°	
	ブーム角 (°)	荷重 (ton)	ブーム角 (°)	荷重 (ton)	ブーム角 (°)	荷重 (ton)	ブーム角 (°)	荷重 (ton)	ブーム角 (°)	荷重 (ton)
14.0	80.3	12.0								
16.0	78.9	12.0								
18.0	77.4	12.0								
20.0	75.9	12.0	79.5	11.2						
22.0	74.4	12.0	77.9	10.7						
24.0	72.8	11.4	76.2	10.2						
26.0	71.1	10.6	74.5	9.6	79.2	7.9				
28.0	69.4	9.9	72.8	9.1	77.4	7.6				
30.0	67.7	9.2	71.1	8.6	75.7	7.4	79.4	6.3		
32.0	65.9	8.6	69.3	8.1	73.8	7.2	77.4	6.1	80.0	5.4
34.0	64.1	8.1	67.5	7.7	71.9	7.0	75.4	6.0	77.7	5.3
36.0	62.2	7.6	65.6	7.4	70.0	6.8	73.3	5.8	75.4	5.2
38.0	60.3	7.2	63.7	7.0	68.0	6.6	71.1	5.7	73.0	5.2
40.0	58.4	6.8	61.8	6.7	65.9	6.4	68.9	5.5	70.4	5.1
42.0	56.4	6.4	59.7	6.4	63.8	6.2	66.6	5.4	67.9	5.1
44.0	54.4	6.1	57.6	6.1	61.6	6.0	64.2	5.3	65.1	5.1
46.0	52.2	5.8	55.4	5.9	59.4	5.8	61.7	5.3	62.1	5.1
48.0	49.9	5.5	53.2	5.7	56.9	5.7	59.0	5.2		
50.0	47.7	5.2	50.9	5.5	54.4	5.5	56.1	5.1		
52.0	45.2	4.9	48.4	5.3	51.7	5.3	53.0	5.1		
54.0	42.4	4.1	45.6	4.7	48.7	5.1	49.6	5.0		
56.0	39.5	3.4	42.6	3.9	45.5	4.5				
58.0	36.3	2.7	39.3	3.2	41.8	3.7				
60.0	32.9	2.1	35.7	2.5	37.7	2.9				
62.0	29.1	1.5	31.5	1.8	32.6	2.1				
掛数	1		1		1		1		1	
危険角度(°)	23		23		30		45		60	
フック種類	12t		12t		12t		12t		12t	
フック質量(t)	0.42		0.42		0.42		0.42		0.42	

SA性能

45.5mブーム+2.0m+27.0mSLジブ

オフセット	5°		15°		30°		45°		60°	
	ブーム角 (°)	荷重 (ton)	ブーム角 (°)	荷重 (ton)	ブーム角 (°)	荷重 (ton)	ブーム角 (°)	荷重 (ton)	ブーム角 (°)	荷重 (ton)
16.0	79.8	11.0								
18.0	78.4	11.0								
20.0	77.1	11.0	80.5	11.0						
22.0	75.7	11.0	79.2	10.9						
24.0	74.3	11.0	77.6	10.4						
26.0	73.0	11.0	76.2	10.0	80.3	8.0				
28.0	71.5	10.5	74.6	9.4	78.8	7.8				
30.0	69.9	9.8	73.0	8.9	77.1	7.5				
32.0	68.3	9.2	71.4	8.5	75.5	7.3	78.8	6.2		
34.0	66.6	8.6	69.8	8.1	73.8	7.1	76.9	6.0	79.2	5.3
36.0	65.0	8.1	68.1	7.7	72.1	7.0	75.2	5.9	77.1	5.3
38.0	63.3	7.7	66.4	7.4	70.3	6.8	73.3	5.8	75.0	5.2
40.0	61.5	7.3	64.6	7.0	68.5	6.4	71.3	5.6	72.8	5.1
42.0	59.7	6.9	62.8	6.7	66.5	6.1	69.3	5.5	70.6	5.1
44.0	57.9	6.5	60.9	6.4	64.6	5.8	67.2	5.4	68.1	5.1
46.0	56.0	6.2	59.0	6.0	62.6	5.5	64.9	5.1	65.7	5.0
48.0	54.1	5.8	57.1	5.7	60.4	5.2	62.7	4.9	63.0	4.8
50.0	52.0	5.4	54.9	5.2	58.3	4.9	60.2	4.7		
52.0	49.8	4.6	52.7	4.9	56.0	4.7	57.6	4.5		
54.0	47.4	3.8	50.5	4.5	53.6	4.4	55.0	4.3		
56.0	44.9	3.1	47.9	3.7	51.0	4.1	51.9	4.1		
58.0	42.3	2.4	45.2	3.0	48.1	3.6	48.7	3.8		
60.0	39.5	1.8	42.3	2.3	45.0	2.8				
62.0			39.3	1.6	41.5	2.1				
64.0					37.6	1.4				
掛数	1		1		1		1		1	
危険角度(°)	34		35		35		45		60	
フック種類	12t		12t		12t		12t		12t	
フック質量(t)	0.42		0.42		0.42		0.42		0.42	

SA性能

50.0mブーム+2.0m+27.0mSLジブ

オフセット	5°		15°		30°		45°		60°	
	ブーム角 (°)	荷重 (ton)	ブーム角 (°)	荷重 (ton)	ブーム角 (°)	荷重 (ton)	ブーム角 (°)	荷重 (ton)	ブーム角 (°)	荷重 (ton)
18.0	79.1	9.0								
20.0	77.9	9.0								
22.0	76.7	9.0	79.9	9.0						
24.0	75.4	9.0	78.6	9.0						
26.0	74.1	9.0	77.3	9.0						
28.0	72.9	9.0	76.0	9.0	80.0	7.9				
30.0	71.6	9.0	74.7	9.0	78.5	7.6				
32.0	70.3	9.0	73.3	8.8	77.0	7.4	80.1	6.3		
34.0	68.9	9.0	71.8	8.4	75.5	7.3	78.4	6.1		
36.0	67.4	8.6	70.3	7.9	73.9	7.0	76.8	6.0	78.6	5.3
38.0	65.9	8.0	68.6	7.3	72.3	6.6	75.0	5.8	76.7	5.2
40.0	64.3	7.4	67.0	6.8	70.6	6.2	73.3	5.7	74.8	5.2
42.0	62.5	6.8	65.3	6.3	68.9	5.8	71.5	5.4	72.8	5.1
44.0	60.9	6.2	63.6	5.9	67.1	5.4	69.5	5.1	70.7	4.9
46.0	59.1	5.7	61.9	5.5	65.3	5.1	67.6	4.8	68.5	4.7
48.0	57.3	5.2	60.0	5.1	63.4	4.7	65.6	4.5	66.2	4.4
50.0	55.5	4.8	58.2	4.7	61.4	4.4	63.4	4.2	63.8	4.2
52.0	53.6	4.3	56.2	4.3	59.5	4.2	61.3	4.0		
54.0	51.5	3.5	54.3	3.9	57.3	3.9	59.0	3.8		
56.0	49.3	2.8	52.2	3.5	55.2	3.6	56.5	3.6		
58.0	47.0	2.2	49.8	2.8	52.8	3.3	53.9	3.3		
60.0	44.6	1.5	47.4	2.1	50.3	2.8	51.1	3.0		
62.0			44.9	1.5	47.5	2.0				
64.0					44.5	1.3				
掛数	1		1		1		1		1	
危険角度(°)	42		42		42		45		60	
フック種類	12t		12t		12t		12t		12t	
フック質量(t)	0.42		0.42		0.42		0.42		0.42	

SA性能

40.9mブーム+2.0m+31.0mSLジブ

オフセット 作業半径	5°		15°		30°		45°		60°	
	ブーム角 (°)	荷重 (ton)	ブーム角 (°)	荷重 (ton)	ブーム角 (°)	荷重 (ton)	ブーム角 (°)	荷重 (ton)	ブーム角 (°)	荷重 (ton)
16.0	79.7	9.0								
18.0	78.3	9.0								
20.0	76.9	9.0								
22.0	75.5	9.0	79.6	9.0						
24.0	74.1	9.0	78.1	8.7						
26.0	72.7	9.0	76.5	8.3						
28.0	71.2	8.9	74.9	8.0	80.0	6.4				
30.0	69.6	8.3	73.3	7.6	78.4	6.2				
32.0	67.9	7.8	71.7	7.3	76.7	6.1				
34.0	66.2	7.3	70.0	6.9	74.9	5.9	79.0	4.9		
36.0	64.5	6.8	68.3	6.6	73.2	5.7	77.0	4.8		
38.0	62.8	6.4	66.4	6.2	71.2	5.5	75.1	4.7	77.7	4.2
40.0	61.0	6.1	64.6	5.9	69.4	5.3	73.1	4.6	75.4	4.2
42.0	59.1	5.7	62.8	5.7	67.5	5.1	70.9	4.5	73.0	4.1
44.0	57.2	5.4	60.9	5.4	65.5	5.0	68.8	4.4	70.5	4.1
46.0	55.3	5.1	59.0	5.2	63.4	4.8	66.5	4.3	67.8	4.0
48.0	53.4	4.9	56.9	5.0	61.2	4.7	64.0	4.2	64.9	4.0
50.0	51.2	4.6	54.8	4.8	59.0	4.6	61.6	4.2	62.0	4.0
52.0	49.1	4.4	52.7	4.6	56.6	4.5	58.9	4.1		
54.0	46.9	4.2	50.3	4.4	54.2	4.4	56.1	4.1		
56.0	44.5	4.0	47.9	4.3	51.6	4.3	52.9	4.0		
58.0	41.9	3.5	45.3	4.1	48.7	4.2	49.5	4.0		
60.0	39.0	2.8	42.4	3.4	45.5	4.0				
62.0	35.9	2.2	39.1	2.7	41.9	3.2				
64.0	32.5	1.7	35.5	2.1	37.6	2.5				
66.0			31.5	1.5	32.6	1.7				
72.0										
掛数	1		1		1		1		1	
危険角度(°)	26		26		30		45		60	
フック種類	12t		12t		12t		12t		12t	
フック質量(t)	0.42		0.42		0.42		0.42		0.42	

SA性能

45.5mブーム+2.0m+31.0mSLジブ

オフセット	5°		15°		30°		45°		60°	
	ブーム角 (°)	荷重 (ton)	ブーム角 (°)	荷重 (ton)	ブーム角 (°)	荷重 (ton)	ブーム角 (°)	荷重 (ton)	ブーム角 (°)	荷重 (ton)
18.0	79.3	9.0								
20.0	78.0	9.0								
22.0	76.8	9.0	80.6	9.0						
24.0	75.5	9.0	79.3	9.0						
26.0	74.2	9.0	77.8	8.5						
28.0	72.9	9.0	76.4	8.2						
30.0	71.5	8.8	74.9	7.8	79.6	6.3				
32.0	70.0	8.3	73.5	7.5	78.0	6.1				
34.0	68.5	7.7	72.0	7.2	76.4	6.0	80.2	5.0		
36.0	66.9	7.3	70.4	6.8	74.9	5.8	78.5	4.9		
38.0	65.3	6.9	68.8	6.5	73.2	5.6	76.6	4.7	79.1	4.2
40.0	63.7	6.5	67.1	6.2	71.5	5.4	74.8	4.6	77.1	4.2
42.0	62.1	6.1	65.5	6.0	69.8	5.3	72.9	4.5	75.0	4.1
44.0	60.4	5.8	63.8	5.7	68.0	5.1	71.1	4.5	72.7	4.1
46.0	58.7	5.5	62.0	5.5	66.2	5.0	69.1	4.4	70.5	4.0
48.0	56.9	5.2	60.2	5.2	64.3	4.8	67.0	4.3	68.1	4.0
50.0	55.1	5.0	58.4	5.0	62.2	4.5	64.9	4.2	65.6	4.0
52.0	53.2	4.7	56.5	4.7	60.2	4.3	62.6	4.1	62.9	4.0
54.0	51.3	4.5	54.4	4.4	58.0	4.1	60.2	3.9		
56.0	49.0	3.8	52.3	4.1	55.9	3.9	57.6	3.7		
58.0	46.7	3.1	50.1	3.8	53.4	3.7	54.9	3.6		
60.0	44.2	2.5	47.5	3.1	50.9	3.5	51.9	3.4		
62.0	41.7	1.9	44.9	2.5	48.1	3.2	48.6	3.2		
64.0	39.0	1.4	42.1	1.9	45.0	2.4				
66.0			39.1	1.3	41.5	1.8				
掛数	1		1		1		1		1	
危険角度(°)	36		36		36		45		60	
フック種類	12t		12t		12t		12t		12t	
フック質量(t)	0.42		0.42		0.42		0.42		0.42	

SA性能

50.0mブーム+2.0m+31.0mSLジブ

オフセット	5°		15°		30°		45°		60°	
	ブーム角 (°)	荷重 (ton)	ブーム角 (°)	荷重 (ton)	ブーム角 (°)	荷重 (ton)	ブーム角 (°)	荷重 (ton)	ブーム角 (°)	荷重 (ton)
18.0	80.0	8.0								
20.0	78.8	8.0								
22.0	77.7	8.0								
24.0	76.6	8.0	80.1	8.0						
26.0	75.4	8.0	78.9	8.0						
28.0	74.1	8.0	77.7	8.0						
30.0	72.9	8.0	76.5	8.0	80.6	6.4				
32.0	71.7	8.0	75.0	7.7	79.3	6.2				
34.0	70.5	8.0	73.7	7.4	77.8	6.1				
36.0	69.2	7.7	72.3	7.1	76.4	5.9	79.7	4.9		
38.0	67.7	7.3	70.9	6.8	74.8	5.7	78.1	4.8		
40.0	66.2	6.9	69.4	6.4	73.4	5.5	76.5	4.7	78.6	4.2
42.0	64.7	6.5	67.8	6.0	71.8	5.4	74.8	4.6	76.7	4.1
44.0	63.2	6.0	66.3	5.6	70.2	5.1	73.1	4.5	74.8	4.1
46.0	61.6	5.6	64.6	5.2	68.4	4.7	71.3	4.4	72.8	4.1
48.0	59.9	5.1	62.9	4.8	66.7	4.4	69.4	4.2	70.7	4.0
50.0	58.2	4.7	61.3	4.5	64.9	4.2	67.5	4.0	68.5	3.9
52.0	56.4	4.3	59.4	4.2	63.1	3.9	65.5	3.7	66.1	3.7
54.0	54.7	3.9	57.7	3.9	61.2	3.7	63.4	3.5		
56.0	52.8	3.5	55.8	3.6	59.3	3.4	61.2	3.3		
58.0	50.7	2.8	53.9	3.3	57.1	3.2	58.9	3.1		
60.0	48.5	2.2	51.8	2.9	55.1	3.0	56.5	2.9		
62.0	46.3	1.6	49.4	2.3	52.7	2.7	53.9	2.8		
64.0			47.1	1.6	50.2	2.4	51.1	2.5		
66.0					47.5	1.7				
掛数	1		1		1		1		1	
危険角度(°)	43		43		43		45		60	
フック種類	12t		12t		12t		12t		12t	
フック質量(t)	0.42		0.42		0.42		0.42		0.42	

HA性能

13.6mブーム+4.4m+13.0mヘリフトジブ

オフセット	10°	20°	30°	45°	60°
作業半径	荷重 (ton)	荷重 (ton)	荷重 (ton)	荷重 (ton)	荷重 (ton)
7.0	84.0				
8.0	84.0	84.0			
9.0	84.0	80.1			
10.0	80.8	76.0	65.8		
11.0	75.6	72.2	63.2		
12.0	70.0	68.9	60.7	50.9	
14.0	60.9	61.6	56.6	48.1	34.2
16.0	53.9	54.5	53.1	45.8	33.3
18.0	48.3	48.7	49.3	44.0	32.7
20.0	42.4	43.1	43.7	42.6	
22.0	37.5	38.0	38.5	38.9	
24.0	33.4	33.8	34.1		
26.0	30.0	30.2	30.3		
28.0	27.0				
掛数	8	8	8	8	8
危険角度(°)	10	20	30	45	60
フック種類	150t	150t	150t	150t	150t
フック質量(t)	1.86	1.86	1.86	1.86	1.86

HA性能

18.15mブーム+4.4m+13.0mヘリフトジブ

オフセット	10°	20°	30°	45°	60°
作業半径	荷重 (ton)	荷重 (ton)	荷重 (ton)	荷重 (ton)	荷重 (ton)
7.0	77.0				
8.0	77.0				
9.0	77.0	77.0			
10.0	77.0	77.0			
11.0	77.0	76.2	65.2		
12.0	73.4	72.9	63.0		
14.0	62.2	63.6	59.0	50.6	
16.0	53.6	54.8	55.6	48.4	36.2
18.0	46.2	47.4	48.4	46.5	35.5
20.0	40.2	41.1	42.0	43.0	35.1
22.0	35.3	36.0	36.7	37.5	
24.0	31.2	31.8	32.3	32.9	
26.0	27.7	28.2	28.6	28.9	
28.0	24.7	25.1	25.4		
30.0	22.2	22.4	22.5		
32.0	19.9				
掛数	8	8	8	8	8
危険角度(°)	10	20	30	45	60
フック種類	150t	150t	150t	150t	150t
フック質量(t)	1.86	1.86	1.86	1.86	1.86

HA性能

22.7mブーム+4.4m+13.0mヘビークラフジブ

オフセット	10°	20°	30°	45°	60°
作業半径	荷重 (ton)	荷重 (ton)	荷重 (ton)	荷重 (ton)	荷重 (ton)
8.0	64.0				
9.0	64.0				
10.0	64.0	64.0			
11.0	64.0	64.0			
12.0	64.0	64.0	64.0		
14.0	60.9	62.6	61.2	51.8	
16.0	52.2	53.6	55.0	49.8	38.6
18.0	44.7	46.1	47.3	48.2	37.8
20.0	38.7	39.8	40.9	42.1	37.3
22.0	33.7	34.7	35.6	36.6	36.9
24.0	29.6	30.4	31.1	32.0	
26.0	26.1	26.8	27.4	28.0	
28.0	23.1	23.7	24.2	24.6	
30.0	20.5	21.0	21.3		
32.0	18.3	18.6	18.9		
34.0	16.3	16.5	16.6		
36.0	14.5	14.6			
掛数	6	6	6	6	6
危険角度(°)	10	20	30	45	60
フック種類	83t	83t	83t	83t	83t
フック質量(t)	1.00	1.00	1.00	1.00	1.00

HA性能

31.8mブーム+4.4m+13.0mヘビークラフジブ

オフセット	10°	20°	30°	45°	60°
作業半径	荷重 (ton)	荷重 (ton)	荷重 (ton)	荷重 (ton)	荷重 (ton)
10.0	45.0				
11.0	44.8	40.3			
12.0	44.1	39.8			
14.0	42.8	38.8	35.3		
16.0	41.7	38.0	34.7	30.2	
18.0	40.7	37.2	34.1	29.8	25.8
20.0	37.0	36.6	33.7	29.6	25.8
22.0	33.2	34.0	33.3	29.5	25.8
24.0	29.4	30.4	31.2	29.4	25.8
26.0	25.9	26.7	27.5	28.3	25.8
28.0	22.9	23.6	24.3	25.0	25.3
30.0	20.3	20.9	21.5	22.1	
32.0	18.0	18.6	19.1	19.5	
34.0	16.0	16.5	16.9	17.2	
36.0	14.2	14.6	15.0		
38.0	12.6	13.0	13.2		
40.0	11.2	11.5	11.6		
42.0	9.9	10.1			
44.0	8.7	8.8			
46.0	7.4				
掛数	4	4	4	4	4
危険角度(°)	10	20	30	45	60
フック種類	83t	83t	83t	83t	83t
フック質量(t)	1.00	1.00	1.00	1.00	1.00

HA性能

13.6mブーム+4.4m+22.0mヒールリフトジブ

オフセット	10°	20°	30°	45°	60°
作業半径	荷重 (ton)	荷重 (ton)	荷重 (ton)	荷重 (ton)	荷重 (ton)
10.0	54.0				
11.0	54.0				
12.0	54.0				
14.0	54.0	47.4			
16.0	49.9	43.1	38.0		
18.0	45.0	39.5	35.3		
20.0	41.1	36.6	33.0	28.1	
22.0	37.7	34.0	31.0	26.8	19.4
24.0	34.9	31.8	29.3	25.7	18.9
26.0	31.9	30.0	27.9	24.7	18.6
28.0	28.9	28.3	26.6	23.9	18.4
30.0	26.3	26.7	25.6	23.4	
32.0	23.9	24.2	24.6	23.1	
34.0	21.8	22.1	22.3		
36.0	20.0	20.1			
掛数	6	6	6	6	6
危険角度(°)	10	20	30	45	60
フック種類	83t	83t	83t	83t	83t
フック質量(t)	1.00	1.00	1.00	1.00	1.00

HA性能

18.15mブーム+4.4m+22.0mヒールリフトジブ

オフセット	10°	20°	30°	45°	60°
作業半径	荷重 (ton)	荷重 (ton)	荷重 (ton)	荷重 (ton)	荷重 (ton)
10.0	50.0				
11.0	50.0				
12.0	50.0				
14.0	50.0	49.4			
16.0	50.0	45.2			
18.0	48.8	41.7	36.4		
20.0	42.7	38.7	34.3		
22.0	37.7	36.2	32.3	28.2	
24.0	33.5	33.9	30.7	27.1	20.6
26.0	29.9	31.0	29.2	26.2	20.2
28.0	26.9	27.8	27.9	25.4	19.9
30.0	24.3	25.1	25.9	24.7	19.7
32.0	22.0	22.7	23.3	24.0	
34.0	20.0	20.6	21.1	21.5	
36.0	18.2	18.7	19.0		
38.0	16.6	16.9	17.2		
40.0	15.1	15.4			
42.0	12.1				
掛数	6	6	6	6	6
危険角度(°)	10	20	30	45	60
フック種類	83t	83t	83t	83t	83t
フック質量(t)	1.00	1.00	1.00	1.00	1.00

HA性能

22.7mブーム+4.4m+22.0mヘビークラフジブ

オフセット 作業半径	10° 荷重 (ton)	20° 荷重 (ton)	30° 荷重 (ton)	45° 荷重 (ton)	60° 荷重 (ton)
11.0	45.0				
12.0	45.0				
14.0	45.0				
16.0	45.0	45.0			
18.0	45.0	45.0	39.5		
20.0	41.4	43.0	37.2		
22.0	36.4	38.1	35.2	30.0	
24.0	32.2	33.7	33.4	28.9	22.1
26.0	28.6	29.9	31.2	27.9	21.7
28.0	25.6	26.7	27.8	27.0	21.3
30.0	22.9	23.9	24.9	26.1	21.1
32.0	20.6	21.5	22.3	23.4	20.9
34.0	18.6	19.3	20.1	20.9	
36.0	16.7	17.4	18.0	18.7	
38.0	15.1	15.7	16.2	16.6	
40.0	13.6	14.1	14.5		
42.0	12.3	12.7	12.9		
44.0	11.1	11.3			
46.0	10.0				
掛数	4	4	4	4	4
危険角度(°)	10	20	30	45	60
フック種類	83t	83t	83t	83t	83t
フック質量(t)	1.00	1.00	1.00	1.00	1.00

HA性能

31.8mブーム+4.4m+22.0mヘビークラフジブ

オフセット 作業半径	10° 荷重 (ton)	20° 荷重 (ton)	30° 荷重 (ton)	45° 荷重 (ton)	60° 荷重 (ton)
14.0	30.0				
16.0	30.0	29.8			
18.0	30.0	28.9			
20.0	30.0	28.0	25.2		
22.0	30.0	27.3	24.6		
24.0	29.2	26.6	24.1	20.6	
26.0	27.8	26.0	23.7	20.3	17.0
28.0	24.8	25.5	23.3	20.1	16.9
30.0	22.1	23.3	22.9	19.9	16.9
32.0	19.8	20.9	21.9	19.7	16.9
34.0	17.8	18.8	19.7	19.7	16.9
36.0	16.0	16.9	17.6	18.6	16.9
38.0	14.3	15.1	15.8	16.6	
40.0	12.9	13.6	14.2	14.9	
42.0	11.6	12.2	12.7	13.2	
44.0	10.4	10.9	11.4	11.7	
46.0	9.3	9.7	10.1		
48.0	8.3	8.7	8.9		
50.0	7.4	7.7	7.8		
55.0	5.1				
掛数	4	4	4	4	4
危険角度(°)	10	20	30	45	60
フック種類	83t	83t	83t	83t	83t
フック質量(t)	1.00	1.00	1.00	1.00	1.00

HA性能

40.9mブーム+4.4m+22.0mヘビーフジブ

オフセット 作業半径	10° 荷重 (ton)	20° 荷重 (ton)	30° 荷重 (ton)	45° 荷重 (ton)	60° 荷重 (ton)
16.0	20.0				
18.0	20.0				
20.0	20.0	20.0			
22.0	20.0	20.0	20.0		
24.0	20.0	20.0	20.0		
26.0	20.0	20.0	20.0	20.0	
28.0	20.0	20.0	20.0	20.0	20.0
30.0	20.0	20.0	20.0	20.0	20.0
32.0	19.5	20.0	20.0	20.0	20.0
34.0	17.5	18.7	19.5	20.0	20.0
36.0	15.7	16.7	17.6	18.8	19.3
38.0	14.1	15.0	15.8	16.8	17.4
40.0	12.6	13.5	14.2	15.1	15.5
42.0	11.3	12.1	12.7	13.5	
44.0	10.1	10.8	11.4	12.0	
46.0	9.0	9.6	10.1	10.7	
48.0	8.0	8.5	9.0	9.4	
50.0	7.0	7.5	7.9	8.2	
55.0	5.0	5.3	5.6		
60.0	3.3	3.4			
掛数	2	2	2	2	2
危険角度(°)	20	20	30	45	60
フック種類	24t	24t	24t	24t	24t
フック質量(t)	0.88	0.88	0.88	0.88	0.88

HA性能

45.5mブーム+4.4m+22.0mヘビーフジブ

オフセット 作業半径	10° 荷重 (ton)	20° 荷重 (ton)	30° 荷重 (ton)	45° 荷重 (ton)	60° 荷重 (ton)
16.0	16.0				
18.0	16.0				
20.0	16.0	16.0			
22.0	16.0	16.0			
24.0	16.0	16.0	16.0		
26.0	16.0	16.0	16.0		
28.0	16.0	16.0	16.0	15.6	
30.0	16.0	16.0	16.0	15.4	13.0
32.0	16.0	16.0	16.0	15.3	13.0
34.0	16.0	16.0	16.0	15.2	12.9
36.0	15.5	16.0	16.0	15.1	12.9
38.0	13.8	14.8	15.7	15.1	12.9
40.0	12.4	13.3	14.1	15.0	12.9
42.0	11.0	11.9	12.6	13.4	12.9
44.0	9.8	10.6	11.2	12.0	
46.0	8.7	9.4	10.0	10.6	
48.0	7.7	8.3	8.9	9.4	
50.0	6.8	7.4	7.8	8.3	
55.0	4.7	5.2	5.5		
60.0	3.0	3.3	3.5		
掛数	2	2	2	2	2
危険角度(°)	25	26	30	45	60
フック種類	24t	24t	24t	24t	24t
フック質量(t)	0.88	0.88	0.88	0.88	0.88

HA性能

50.0mブーム+4.4m+22.0mヘビーリフトジブ

オフセット	10°	20°	30°	45°	60°
作業半径	荷重 (ton)	荷重 (ton)	荷重 (ton)	荷重 (ton)	荷重 (ton)
18.0	11.0				
20.0	11.0				
22.0	11.0	11.0			
24.0	11.0	11.0	11.0		
26.0	11.0	11.0	11.0		
28.0	11.0	11.0	10.9	9.1	
30.0	11.0	11.0	10.8	9.1	7.5
32.0	11.0	11.0	10.6	9.0	7.5
34.0	11.0	11.0	10.5	9.0	7.5
36.0	11.0	11.0	10.4	8.9	7.5
38.0	11.0	11.0	10.4	8.9	7.5
40.0	11.0	11.0	10.3	8.9	7.5
42.0	10.6	11.0	10.3	8.9	7.5
44.0	9.6	10.3	10.3	8.9	7.5
46.0	8.5	9.2	9.9	8.9	
48.0	7.5	8.2	8.8	8.9	
50.0	6.6	7.2	7.7	8.3	
55.0	4.5	5.0	5.4	5.8	
60.0	2.8	3.2	3.5		
掛数	2	2	2	2	2
危険角度(°)	34	34	34	45	60
フック種類	24t	24t	24t	24t	24t
フック質量(t)	0.88	0.88	0.88	0.88	0.88

HA性能

13.6mブーム+4.4m+31.0mヘビークラフジブ

オフセット	10°	20°	30°	45°	60°
作業半径	荷重 (ton)	荷重 (ton)	荷重 (ton)	荷重 (ton)	荷重 (ton)
14.0	35.0				
16.0	34.4				
18.0	34.4	33.8			
20.0	34.4	31.5			
22.0	32.8	29.1	26.1		
24.0	30.2	27.1	24.5		
26.0	27.9	25.3	23.1		
28.0	26.0	23.7	21.8	18.8	
30.0	24.3	22.4	20.7	18.0	
32.0	22.8	21.2	19.7	17.3	12.7
34.0	21.5	20.1	18.9	16.7	12.4
36.0	20.3	19.1	18.1	16.2	12.2
38.0	19.3	18.3	17.4	15.8	
40.0	17.8	17.6	16.9	15.5	
42.0	16.5	16.8	16.4		
44.0	15.4	15.6	15.7		
46.0	14.3				
掛数	4	4	4	4	4
危険角度(°)	10	20	30	45	60
フック種類	83t	83t	83t	83t	83t
フック質量(t)	1.00	1.00	1.00	1.00	1.00

HA性能

18.15mブーム+4.4m+31.0mヘビークラフジブ

オフセット	10°	20°	30°	45°	60°
作業半径	荷重 (ton)	荷重 (ton)	荷重 (ton)	荷重 (ton)	荷重 (ton)
14.0	34.0				
16.0	34.0				
18.0	34.0	34.0			
20.0	34.0	32.8			
22.0	34.0	30.4	26.8		
24.0	32.4	28.4	25.2		
26.0	30.1	26.6	23.8		
28.0	28.0	25.0	22.6	19.8	
30.0	25.8	23.6	21.5	19.1	
32.0	23.4	22.4	20.6	18.4	13.9
34.0	21.4	21.3	19.7	17.8	13.6
36.0	19.5	20.3	18.9	17.3	13.4
38.0	17.9	18.5	18.2	16.8	13.2
40.0	16.4	17.0	17.5	16.5	
42.0	15.1	15.6	16.1	16.2	
44.0	13.9	14.4	14.7	15.1	
46.0	12.8	13.2	13.5		
48.0	11.8	12.1	12.3		
50.0	10.9				
掛数	4	4	4	4	4
危険角度(°)	10	20	30	45	60
フック種類	83t	83t	83t	83t	83t
フック質量(t)	1.00	1.00	1.00	1.00	1.00

HA性能

22.7mブーム+4.4m+31.0mヘビーリフトジブ

オフセット	10°	20°	30°	45°	60°
作業半径	荷重 (ton)	荷重 (ton)	荷重 (ton)	荷重 (ton)	荷重 (ton)
16.0	30.0				
18.0	30.0				
20.0	30.0	30.0			
22.0	30.0	30.0			
24.0	30.0	29.6	25.8		
26.0	30.0	27.8	24.5		
28.0	27.0	26.2	23.3		
30.0	24.3	24.8	22.2	19.4	
32.0	22.0	23.3	21.3	18.7	
34.0	19.9	21.1	20.4	18.2	14.5
36.0	18.1	19.2	19.7	17.7	14.2
38.0	16.4	17.4	18.3	17.2	14.1
40.0	15.0	15.9	16.7	16.8	13.9
42.0	13.6	14.4	15.2	15.9	
44.0	12.4	13.1	13.8	14.5	
46.0	11.3	11.9	12.5	13.1	
48.0	10.3	10.8	11.3		
50.0	9.4	9.8	10.1		
55.0	7.3				
掛数	4	4	4	4	4
危険角度(°)	10	20	30	45	60
フック種類	83t	83t	83t	83t	83t
フック質量(t)	1.00	1.00	1.00	1.00	1.00

HA性能

31.8mブーム+4.4m+31.0mヘビーリフトジブ

オフセット	10°	20°	30°	45°	60°
作業半径	荷重 (ton)	荷重 (ton)	荷重 (ton)	荷重 (ton)	荷重 (ton)
16.0	20.0				
18.0	20.0				
20.0	20.0				
22.0	20.0	20.0			
24.0	20.0	20.0			
26.0	20.0	20.0	19.4		
28.0	20.0	20.0	18.9		
30.0	20.0	20.0	18.5	15.6	
32.0	20.0	19.9	18.1	15.3	
34.0	19.4	19.5	17.7	15.1	12.4
36.0	17.5	18.8	17.4	14.9	12.3
38.0	15.9	17.1	17.1	14.7	12.3
40.0	14.4	15.5	16.5	14.6	12.2
42.0	13.0	14.0	15.0	14.5	12.2
44.0	11.8	12.7	13.6	14.4	12.2
46.0	10.7	11.5	12.3	13.2	12.2
48.0	9.7	10.4	11.1	11.9	
50.0	8.7	9.4	10.0	10.6	
55.0	6.6	7.1	7.5		
60.0	4.9	5.2			
掛数	2	2	2	2	2
危険角度(°)	10	20	30	45	60
フック種類	24t	24t	24t	24t	24t
フック質量(t)	0.88	0.88	0.88	0.88	0.88

HA性能

40.9mブーム+4.4m+31.0mヘビークラフジブ

オフセット	10°	20°	30°	45°	60°
作業半径	荷重 (ton)	荷重 (ton)	荷重 (ton)	荷重 (ton)	荷重 (ton)
18.0	14.0				
20.0	14.0				
22.0	14.0				
24.0	14.0	14.0			
26.0	14.0	14.0			
28.0	14.0	14.0	14.0		
30.0	14.0	14.0	14.0		
32.0	14.0	14.0	14.0		
34.0	14.0	14.0	14.0	14.0	
36.0	14.0	14.0	14.0	14.0	
38.0	14.0	14.0	14.0	14.0	14.0
40.0	13.7	14.0	14.0	14.0	14.0
42.0	12.4	13.5	14.0	14.0	14.0
44.0	11.1	12.2	13.2	14.0	14.0
46.0	10.0	11.0	11.9	13.0	13.6
48.0	9.0	9.9	10.7	11.7	12.3
50.0	8.0	8.9	9.6	10.5	10.9
55.0	5.9	6.6	7.2	7.8	
60.0	4.2	4.7	5.2	5.5	
65.0	2.8	3.1	3.4		
掛数	2	2	2	2	2
危険角度(°)	25°	26°	30°	45°	60°
フック種類	24t	24t	24t	24t	24t
フック質量(t)	0.88	0.88	0.88	0.88	0.88

HA性能

45.5mブーム+4.4m+31.0mヘビークラフジブ

オフセット	10°	20°	30°	45°	60°
作業半径	荷重 (ton)	荷重 (ton)	荷重 (ton)	荷重 (ton)	荷重 (ton)
20.0	12.0				
22.0	12.0				
24.0	12.0	12.0			
26.0	12.0	12.0			
28.0	12.0	12.0			
30.0	12.0	12.0	12.0		
32.0	12.0	12.0	12.0		
34.0	12.0	12.0	12.0	11.1	
36.0	12.0	12.0	12.0	11.0	
38.0	12.0	12.0	12.0	10.9	8.9
40.0	12.0	12.0	12.0	10.8	8.9
42.0	12.0	12.0	12.0	10.7	8.8
44.0	10.8	11.9	12.0	10.6	8.8
46.0	9.7	10.7	11.7	10.6	8.8
48.0	8.7	9.6	10.5	10.5	8.8
50.0	7.7	8.6	9.4	10.4	8.8
55.0	5.6	6.4	7.0	7.8	
60.0	3.9	4.5	5.0	5.5	
65.0		2.9	3.3		
掛数	2	2	2	2	2
危険角度(°)	34	35	35	45	60
フック種類	24t	24t	24t	24t	24t
フック質量(t)	0.88	0.88	0.88	0.88	0.88

HA性能

50.0mブーム+4.4m+31.0mヘリフトジブ

オフセット	10°	20°	30°	45°	60°
作業半径	荷重 (ton)	荷重 (ton)	荷重 (ton)	荷重 (ton)	荷重 (ton)
20.0	9.0				
22.0	9.0				
24.0	9.0				
26.0	9.0	9.0			
28.0	9.0	9.0			
30.0	9.0	9.0	7.8		
32.0	9.0	8.8	7.7		
34.0	9.0	8.6	7.5		
36.0	9.0	8.4	7.4	6.0	
38.0	9.0	8.2	7.3	5.9	4.7
40.0	9.0	8.1	7.2	5.9	4.6
42.0	8.9	8.0	7.1	5.8	4.6
44.0	8.7	7.9	7.0	5.8	4.6
46.0	8.6	7.8	7.0	5.8	4.6
48.0	8.3	7.7	6.9	5.8	4.6
50.0	7.4	7.6	6.9	5.8	4.6
55.0	5.4	6.2	6.9	5.8	
60.0	3.6	4.3	4.9	5.5	
65.0		2.7	3.1	3.5	
掛数	2	2	2	2	2
危険角度(°)	40	41	41	45	60
フック種類	24t	24t	24t	24t	24t
フック質量(t)	0.88	0.88	0.88	0.88	0.88

HA性能

13.6mブーム+4.4m+40.0mヘビークラフ

オフセット	10°	20°	30°	45°	60°
作業半径	荷重 (ton)	荷重 (ton)	荷重 (ton)	荷重 (ton)	荷重 (ton)
16.0	12.0				
18.0	12.0				
20.0	12.0				
22.0	12.0	12.0			
24.0	12.0	12.0			
26.0	12.0	12.0			
28.0	12.0	12.0	12.0		
30.0	12.0	12.0	12.0		
32.0	12.0	12.0	12.0		
34.0	12.0	12.0	12.0		
36.0	12.0	12.0	12.0	11.8	
38.0	12.0	12.0	12.0	11.2	
40.0	12.0	12.0	11.9	10.7	9.4
42.0	12.0	12.0	11.3	10.2	9.2
44.0	12.0	11.5	10.7	9.8	9.0
46.0	11.6	10.9	10.3	9.5	8.9
48.0	10.9	10.3	9.8	9.2	
50.0	10.3	9.9	9.5	9.0	
55.0	9.2				
掛数	1	1	1	1	1
危険角度(°)	10	20	30	45	60
フック種類	12t	12t	12t	12t	12t
フック質量(t)	0.53	0.53	0.53	0.53	0.53

HA性能

18.15mブーム+4.4m+40.0mヘビークラフ

オフセット	10°	20°	30°	45°	60°
作業半径	荷重 (ton)	荷重 (ton)	荷重 (ton)	荷重 (ton)	荷重 (ton)
18.0	12.0				
20.0	12.0				
22.0	12.0				
24.0	12.0	12.0			
26.0	12.0	12.0			
28.0	12.0	12.0			
30.0	12.0	12.0	12.0		
32.0	12.0	12.0	12.0		
34.0	12.0	12.0	12.0		
36.0	12.0	12.0	12.0	12.0	
38.0	12.0	12.0	12.0	11.5	
40.0	12.0	12.0	12.0	11.0	9.9
42.0	12.0	12.0	11.9	10.6	9.6
44.0	12.0	12.0	11.4	10.2	9.3
46.0	12.0	11.7	10.9	9.8	9.2
48.0	12.0	11.2	10.4	9.5	9.0
50.0	11.4	10.6	10.0	9.3	
55.0	10.0	9.6	9.2		
60.0	7.9				
掛数	1	1	1	1	1
危険角度(°)	10	20	30	45	60
フック種類	12t	12t	12t	12t	12t
フック質量(t)	0.53	0.53	0.53	0.53	0.53

HA性能

22.7mブーム+4.4m+40.0mヘビークラップ

オフセット	10°	20°	30°	45°	60°
作業半径	荷重 (ton)	荷重 (ton)	荷重 (ton)	荷重 (ton)	荷重 (ton)
18.0	12.0				
20.0	12.0				
22.0	12.0				
24.0	12.0	12.0			
26.0	12.0	12.0			
28.0	12.0	12.0			
30.0	12.0	12.0	12.0		
32.0	12.0	12.0	12.0		
34.0	12.0	12.0	12.0		
36.0	12.0	12.0	12.0	12.0	
38.0	12.0	12.0	12.0	11.7	
40.0	12.0	12.0	12.0	11.3	
42.0	12.0	12.0	12.0	10.8	9.7
44.0	12.0	12.0	11.9	10.5	9.5
46.0	12.0	12.0	11.4	10.1	9.3
48.0	11.9	11.9	10.9	9.8	9.1
50.0	11.0	11.4	10.5	9.5	9.0
55.0	8.8	9.4	9.6	9.1	
60.0	7.0	7.4	7.7		
掛数	1	1	1	1	1
危険角度(°)	10	20	30	45	60
フック種類	12t	12t	12t	12t	12t
フック質量(t)	0.53	0.53	0.53	0.53	0.53

HA性能

31.8mブーム+4.4m+40.0mヘビークラップ

オフセット	10°	20°	30°	45°	60°
作業半径	荷重 (ton)	荷重 (ton)	荷重 (ton)	荷重 (ton)	荷重 (ton)
20.0	12.0				
22.0	12.0				
24.0	12.0				
26.0	12.0	12.0			
28.0	12.0	12.0			
30.0	12.0	12.0			
32.0	12.0	12.0	12.0		
34.0	12.0	12.0	12.0		
36.0	12.0	12.0	12.0		
38.0	12.0	12.0	12.0	12.0	
40.0	12.0	12.0	12.0	11.7	
42.0	12.0	12.0	12.0	11.3	
44.0	12.0	12.0	12.0	10.9	9.5
46.0	12.0	12.0	12.0	10.6	9.4
48.0	11.0	12.0	11.9	10.3	9.3
50.0	10.1	11.0	11.5	10.0	9.2
55.0	8.0	8.8	9.5	9.5	9.0
60.0	6.2	6.8	7.4	8.0	
65.0	4.7	5.1	5.5		
70.0	3.3	3.6			
掛数	1	1	1	1	1
危険角度(°)	10	20	30	45	60
フック種類	12t	12t	12t	12t	12t
フック質量(t)	0.53	0.53	0.53	0.53	0.53

HA性能

40.9mブーム+4.4m+40.0mヘビーフック

オフセット	10°	20°	30°	45°	60°
作業半径	荷重 (ton)	荷重 (ton)	荷重 (ton)	荷重 (ton)	荷重 (ton)
22.0	11.0				
24.0	11.0				
26.0	11.0				
28.0	11.0	11.0			
30.0	11.0	11.0			
32.0	11.0	11.0			
34.0	11.0	11.0	11.0		
36.0	11.0	11.0	11.0		
38.0	11.0	11.0	11.0		
40.0	11.0	11.0	11.0		
42.0	11.0	11.0	11.0	11.0	
44.0	11.0	11.0	11.0	11.0	
46.0	11.0	11.0	11.0	11.0	9.6
48.0	10.3	11.0	11.0	10.7	9.5
50.0	9.3	10.5	11.0	10.4	9.3
55.0	7.2	8.2	9.1	9.8	9.1
60.0	5.5	6.3	7.0	7.9	
65.0	4.0	4.6	5.2	5.8	
70.0	2.7	3.2	3.6		
75.0	1.5	1.9	2.1		
掛数	1	1	1	1	1
危険角度(°)	24	25	30	45	60
フック種類	12t	12t	12t	12t	12t
フック質量(t)	0.53	0.53	0.53	0.53	0.53

HA性能

45.5mブーム+4.4m+40.0mヘビーフック

オフセット	10°	20°	30°	45°	60°
作業半径	荷重 (ton)	荷重 (ton)	荷重 (ton)	荷重 (ton)	荷重 (ton)
24.0	10.0				
26.0	10.0				
28.0	10.0				
30.0	10.0	10.0			
32.0	10.0	10.0			
34.0	10.0	10.0			
36.0	10.0	10.0	10.0		
38.0	10.0	10.0	10.0		
40.0	10.0	10.0	10.0		
42.0	10.0	10.0	10.0	8.5	
44.0	10.0	10.0	10.0	8.3	
46.0	10.0	10.0	9.9	8.2	6.6
48.0	10.0	10.0	9.8	8.1	6.5
50.0	9.0	10.0	9.6	8.1	6.5
55.0	6.9	7.9	8.9	7.9	6.5
60.0	5.1	6.0	6.8	7.8	6.5
65.0	3.6	4.4	5.0	5.7	
70.0	2.4	2.9	3.5	3.9	
75.0		1.7	2.0		
掛数	1	1	1	1	1
危険角度(°)	33	34	34	45	60
フック種類	12t	12t	12t	12t	12t
フック質量(t)	0.53	0.53	0.53	0.53	0.53

HA性能

50.0mブーム+4.4m+40.0mヘビーリフトジブ

オフセット	10°	20°	30°	45°	60°
作業半径	荷重 (ton)	荷重 (ton)	荷重 (ton)	荷重 (ton)	荷重 (ton)
24.0	7.0				
26.0	7.0				
28.0	7.0				
30.0	7.0	7.0			
32.0	7.0	7.0			
34.0	7.0	7.0			
36.0	7.0	6.8	5.9		
38.0	7.0	6.7	5.8		
40.0	7.0	6.5	5.6		
42.0	7.0	6.4	5.5		
44.0	7.0	6.2	5.4	4.3	
46.0	6.9	6.1	5.3	4.2	
48.0	6.7	6.0	5.2	4.2	3.1
50.0	6.6	5.9	5.2	4.1	3.1
55.0	6.3	5.7	5.0	4.1	3.1
60.0	4.9	5.5	5.0	4.1	3.1
65.0	3.4	4.1	4.9	4.1	
70.0	2.1	2.7	3.3	3.9	
75.0		1.5	1.9	2.3	
掛数	1	1	1	1	1
危険角度(°)	40	40	40	45	60
フック種類	12t	12t	12t	12t	12t
フック質量(t)	0.53	0.53	0.53	0.53	0.53

HA性能

13.6mブーム+4.4m+47.0mヘビークラフジブ

オフセット	10°	20°	30°	45°	60°
作業半径	荷重 (ton)	荷重 (ton)	荷重 (ton)	荷重 (ton)	荷重 (ton)
18.0	12.0				
20.0	12.0				
22.0	12.0				
24.0	12.0				
26.0	12.0	12.0			
28.0	12.0	12.0			
30.0	12.0	12.0			
32.0	12.0	12.0	12.0		
34.0	12.0	12.0	12.0		
36.0	12.0	12.0	11.7		
38.0	12.0	12.0	10.9		
40.0	12.0	11.2	10.3		
42.0	11.5	10.5	9.7	8.6	
44.0	10.8	9.9	9.2	8.2	
46.0	10.1	9.4	8.7	7.8	7.1
48.0	9.5	8.8	8.2	7.5	6.9
50.0	8.9	8.4	7.9	7.2	6.7
55.0	7.8	7.4	7.1	6.6	
60.0	6.9	6.7	6.5		
掛数	1	1	1	1	1
危険角度(°)	10	20	30	45	60
フック種類	12t	12t	12t	12t	12t
フック質量(t)	0.53	0.53	0.53	0.53	0.53

HA性能

18.15mブーム+4.4m+47.0mヘビークラフジブ

オフセット	10°	20°	30°	45°	60°
作業半径	荷重 (ton)	荷重 (ton)	荷重 (ton)	荷重 (ton)	荷重 (ton)
20.0	12.0				
22.0	12.0				
24.0	12.0				
26.0	12.0	12.0			
28.0	12.0	12.0			
30.0	12.0	12.0			
32.0	12.0	12.0			
34.0	12.0	12.0	12.0		
36.0	12.0	12.0	12.0		
38.0	12.0	12.0	11.3		
40.0	12.0	12.0	10.7		
42.0	12.0	11.2	10.1	8.8	
44.0	11.7	10.6	9.6	8.4	
46.0	11.0	10.0	9.1	8.0	
48.0	10.4	9.5	8.7	7.7	7.0
50.0	9.8	9.0	8.3	7.4	6.8
55.0	8.5	8.0	7.4	6.8	6.5
60.0	7.5	7.1	6.8	6.5	
65.0	6.8	6.6			
掛数	1	1	1	1	1
危険角度(°)	10	20	30	45	60
フック種類	12t	12t	12t	12t	12t
フック質量(t)	0.53	0.53	0.53	0.53	0.53

HA性能

22.7mブーム+4.4m+47.0mヘビークラフジブ

オフセット	10°	20°	30°	45°	60°
作業半径	荷重 (ton)	荷重 (ton)	荷重 (ton)	荷重 (ton)	荷重 (ton)
20.0	12.0				
22.0	12.0				
24.0	12.0				
26.0	12.0				
28.0	12.0	12.0			
30.0	12.0	12.0			
32.0	12.0	12.0			
34.0	12.0	12.0	12.0		
36.0	12.0	12.0	12.0		
38.0	12.0	12.0	11.7		
40.0	12.0	12.0	11.1		
42.0	12.0	11.9	10.5	8.9	
44.0	12.0	11.2	10.0	8.6	
46.0	11.9	10.6	9.5	8.2	
48.0	11.2	10.1	9.1	7.9	7.1
50.0	10.6	9.6	8.7	7.6	6.9
55.0	9.3	8.5	7.8	7.0	6.5
60.0	7.6	7.6	7.2	6.6	
65.0	6.1	6.5	6.7		
70.0	4.8	4.9			
掛数	1	1	1	1	1
危険角度(°)	10	20	30	45	60
フック種類	12t	12t	12t	12t	12t
フック質量(t)	0.53	0.53	0.53	0.53	0.53

HA性能

31.8mブーム+4.4m+47.0mヘビークラフジブ

オフセット	10°	20°	30°	45°	60°
作業半径	荷重 (ton)	荷重 (ton)	荷重 (ton)	荷重 (ton)	荷重 (ton)
22.0	12.0				
24.0	12.0				
26.0	12.0				
28.0	12.0				
30.0	12.0	12.0			
32.0	12.0	12.0			
34.0	12.0	12.0			
36.0	12.0	12.0	12.0		
38.0	12.0	12.0	12.0		
40.0	12.0	12.0	11.8		
42.0	12.0	12.0	11.2		
44.0	12.0	12.0	10.7	8.8	
46.0	12.0	11.8	10.2	8.5	
48.0	11.6	11.2	9.8	8.2	
50.0	10.6	10.6	9.4	8.0	7.0
55.0	8.5	9.5	8.5	7.4	6.7
60.0	6.7	7.5	7.8	6.9	6.5
65.0	5.2	5.9	6.5	6.6	
70.0	3.9	4.4	4.9	5.3	
75.0	2.7	3.1	3.3		
80.0	1.7				
掛数	1	1	1	1	1
危険角度(°)	12	20	30	45	60
フック種類	12t	12t	12t	12t	12t
フック質量(t)	0.53	0.53	0.53	0.53	0.53

HA性能

40.9mブーム+4.4m+47.0mヒールリフトジブ

オフセット	10°	20°	30°	45°	60°
作業半径	荷重 (ton)	荷重 (ton)	荷重 (ton)	荷重 (ton)	荷重 (ton)
26.0	8.0				
28.0	8.0				
30.0	8.0				
32.0	8.0	8.0			
34.0	8.0	8.0			
36.0	8.0	8.0			
38.0	8.0	8.0			
40.0	8.0	8.0	8.0		
42.0	8.0	8.0	8.0		
44.0	8.0	8.0	8.0		
46.0	8.0	8.0	8.0		
48.0	8.0	8.0	8.0	8.0	
50.0	8.0	8.0	8.0	8.0	
55.0	7.7	8.0	8.0	7.7	6.8
60.0	5.9	6.9	7.9	7.2	6.6
65.0	4.4	5.3	6.1	6.9	6.4
70.0	3.1	3.8	4.5	5.2	
75.0	2.0	2.6	3.1	3.5	
80.0		1.4	1.8		
掛数	1	1	1	1	1
危険角度(°)	31	32	32	45	60
フック種類	12t	12t	12t	12t	12t
フック質量(t)	0.53	0.53	0.53	0.53	0.53

HA性能

45.5mブーム+4.4m+47.0mヒールリフトジブ

オフセット	10°	20°	30°	45°	60°
作業半径	荷重 (ton)	荷重 (ton)	荷重 (ton)	荷重 (ton)	荷重 (ton)
26.0	7.5				
28.0	7.5				
30.0	7.5				
32.0	7.5				
34.0	7.5	7.5			
36.0	7.5	7.5			
38.0	7.5	7.5			
40.0	7.5	7.5	7.5		
42.0	7.5	7.5	7.5		
44.0	7.5	7.5	7.5		
46.0	7.5	7.5	7.5		
48.0	7.5	7.5	7.5	6.7	
50.0	7.5	7.5	7.5	6.6	
55.0	7.4	7.5	7.5	6.4	4.9
60.0	5.6	6.7	7.5	6.2	4.9
65.0	4.1	5.0	5.9	6.1	4.9
70.0	2.8	3.6	4.3	5.1	
75.0	1.7	2.3	2.9	3.5	
80.0			1.6		
掛数	1	1	1	1	1
危険角度(°)	38	39	39	45	60
フック種類	12t	12t	12t	12t	12t
フック質量(t)	0.53	0.53	0.53	0.53	0.53

HA性能

50.0mブーム+4.4m+47.0mヒールリフトジブ

オフセット 作業半径	10° 荷重 (ton)	20° 荷重 (ton)	30° 荷重 (ton)	45° 荷重 (ton)	60° 荷重 (ton)
26.0	5.0				
28.0	5.0				
30.0	5.0				
32.0	5.0				
34.0	5.0	5.0			
36.0	5.0	5.0			
38.0	5.0	5.0			
40.0	5.0	5.0	4.5		
42.0	5.0	5.0	4.4		
44.0	5.0	5.0	4.3		
46.0	5.0	4.9	4.2		
48.0	5.0	4.8	4.1	3.1	
50.0	5.0	4.7	4.0	3.0	
55.0	5.0	4.4	3.8	2.9	2.0
60.0	4.8	4.2	3.7	2.8	2.0
65.0	3.8	4.1	3.6	2.8	2.0
70.0	2.5	3.3	3.6	2.8	2.0
75.0	1.4	2.1	2.7	2.8	
80.0			1.5	2.0	
掛数	1	1	1	1	1
危険角度(°)	43	44	44	45	60
フック種類	12t	12t	12t	12t	12t
フック質量(t)	0.53	0.53	0.53	0.53	0.53

HA性能

13.6mブーム+4.4m+54.0mヘビーフットジブ

オフセット	10°	20°	30°	45°	60°
作業半径	荷重 (ton)	荷重 (ton)	荷重 (ton)	荷重 (ton)	荷重 (ton)
22.0	9.3				
24.0	9.3				
26.0	9.3				
28.0	9.3				
30.0	9.1	8.9			
32.0	9.1	8.8			
34.0	9.0	8.8			
36.0	8.9	8.6			
38.0	8.7	8.2	7.7		
40.0	8.4	7.9	7.4		
42.0	8.0	7.6	7.2		
44.0	7.7	7.3	6.9		
46.0	7.4	7.0	6.7	6.2	
48.0	7.1	6.8	6.5	6.1	
50.0	6.9	6.6	6.3	5.9	
55.0	6.3	6.1	5.9	5.4	4.9
60.0	5.8	5.6	5.3	4.9	4.6
65.0	5.2	5.0	4.8		
掛数	1	1	1	1	1
危険角度(°)	10	20	30	45	60
フック種類	12t	12t	12t	12t	12t
フック質量(t)	0.53	0.53	0.53	0.53	0.53

HA性能

18.15mブーム+4.4m+54.0mヘビーフットジブ

オフセット	10°	20°	30°	45°	60°
作業半径	荷重 (ton)	荷重 (ton)	荷重 (ton)	荷重 (ton)	荷重 (ton)
22.0	9.3				
24.0	9.3				
26.0	9.3				
28.0	9.3				
30.0	9.1	9.0			
32.0	9.1	9.0			
34.0	9.1	8.9			
36.0	8.9	8.8			
38.0	8.8	8.4	7.8		
40.0	8.7	8.1	7.6		
42.0	8.4	7.8	7.3		
44.0	8.0	7.5	7.1		
46.0	7.7	7.3	6.8		
48.0	7.5	7.0	6.6	6.1	
50.0	7.2	6.8	6.4	6.0	
55.0	6.6	6.3	6.0	5.5	5.0
60.0	6.1	5.9	5.6	5.0	4.7
65.0	5.6	5.3	5.0	4.7	
70.0	5.0	4.8	4.7		
掛数	1	1	1	1	1
危険角度(°)	10	20	30	45	60
フック種類	12t	12t	12t	12t	12t
フック質量(t)	0.53	0.53	0.53	0.53	0.53

HA性能

22.7mブーム+4.4m+54.0mヘビークラフジブ

オフセット	10°	20°	30°	45°	60°
作業半径	荷重 (ton)	荷重 (ton)	荷重 (ton)	荷重 (ton)	荷重 (ton)
24.0	9.3				
26.0	9.3				
28.0	9.3				
30.0	9.1				
32.0	9.1	8.9			
34.0	9.1	8.8			
36.0	9.0	8.7			
38.0	8.9	8.6	7.9		
40.0	8.8	8.3	7.7		
42.0	8.7	8.0	7.4		
44.0	8.4	7.7	7.2		
46.0	8.1	7.5	7.0		
48.0	7.8	7.2	6.8	6.2	
50.0	7.5	7.0	6.6	6.0	
55.0	6.9	6.5	6.2	5.7	5.1
60.0	6.4	6.1	5.8	5.2	4.8
65.0	6.0	5.7	5.3	4.8	4.6
70.0	5.2	5.2	4.9	4.6	
75.0	4.1	4.4	4.6		
掛数	1	1	1	1	1
危険角度(°)	10	20	30	45	60
フック種類	12t	12t	12t	12t	12t
フック質量(t)	0.53	0.53	0.53	0.53	0.53

HA性能

31.8mブーム+4.4m+54.0mヘビークラフジブ

オフセット	10°	20°	30°	45°	60°
作業半径	荷重 (ton)	荷重 (ton)	荷重 (ton)	荷重 (ton)	荷重 (ton)
26.0	9.0				
28.0	9.0				
30.0	9.0				
32.0	9.0	8.9			
34.0	9.0	8.8			
36.0	9.0	8.7			
38.0	8.9	8.7			
40.0	8.8	8.7	7.9		
42.0	8.7	8.4	7.6		
44.0	8.7	8.1	7.4		
46.0	8.7	7.9	7.2		
48.0	8.4	7.6	7.0		
50.0	8.1	7.4	6.8	6.1	
55.0	7.5	6.9	6.4	5.8	
60.0	6.9	6.5	6.1	5.5	4.9
65.0	5.6	6.1	5.8	5.1	4.7
70.0	4.3	5.0	5.3	4.8	
75.0	3.2	3.7	4.2	4.6	
80.0	2.1	2.6	2.9		
85.0		1.4			
掛数	1	1	1	1	1
危険角度(°)	18	20	30	45	60
フック種類	12t	12t	12t	12t	12t
フック質量(t)	0.53	0.53	0.53	0.53	0.53

HA性能

40.9mブーム+4.4m+54.0mヘビークラフジブ

オフセット	10°	20°	30°	45°	60°
作業半径	荷重 (ton)	荷重 (ton)	荷重 (ton)	荷重 (ton)	荷重 (ton)
28.0	6.0				
30.0	6.0				
32.0	6.0				
34.0	6.0				
36.0	6.0	6.0			
38.0	6.0	6.0			
40.0	6.0	6.0			
42.0	6.0	6.0			
44.0	6.0	6.0	6.0		
46.0	6.0	6.0	6.0		
48.0	6.0	6.0	6.0		
50.0	6.0	6.0	6.0		
55.0	6.0	6.0	6.0	5.9	
60.0	6.0	6.0	6.0	5.7	4.9
65.0	4.8	5.8	6.0	5.3	4.7
70.0	3.5	4.4	5.2	5.0	4.6
75.0	2.4	3.1	3.8	4.6	
80.0	1.4	2.0	2.5	3.1	
85.0			1.4		
掛数	1	1	1	1	1
危険角度(°)	37	38	38	45	60
フック種類	12t	12t	12t	12t	12t
フック質量(t)	0.53	0.53	0.53	0.53	0.53

HA性能

45.5mブーム+4.4m+54.0mヘビークラフジブ

オフセット	10°	20°	30°	45°	60°
作業半径	荷重 (ton)	荷重 (ton)	荷重 (ton)	荷重 (ton)	荷重 (ton)
28.0	5.5				
30.0	5.5				
32.0	5.5				
34.0	5.5				
36.0	5.5	5.5			
38.0	5.5	5.5			
40.0	5.5	5.5			
42.0	5.5	5.5			
44.0	5.5	5.5	5.5		
46.0	5.5	5.5	5.5		
48.0	5.5	5.5	5.5		
50.0	5.5	5.5	5.5		
55.0	5.5	5.5	5.5	5.2	
60.0	5.5	5.5	5.5	5.0	3.7
65.0	4.5	5.5	5.5	4.8	3.6
70.0	3.2	4.1	5.0	4.7	3.6
75.0	2.0	2.8	3.6	4.5	3.6
80.0		1.7	2.3	3.1	
85.0				1.7	
掛数	1	1	1	1	1
危険角度(°)	42	43	44	45	60
フック種類	12t	12t	12t	12t	12t
フック質量(t)	0.53	0.53	0.53	0.53	0.53

HA性能

50.0mブーム+4.4m+54.0mヘビークラフ

オフセット	10°	20°	30°	45°	60°
作業半径	荷重 (ton)	荷重 (ton)	荷重 (ton)	荷重 (ton)	荷重 (ton)
30.0	4.1				
32.0	4.1				
34.0	4.1				
36.0	4.1				
38.0	4.1	4.1			
40.0	4.1	4.1			
42.0	4.1	4.1			
44.0	4.1	4.0			
46.0	4.1	3.9	3.2		
48.0	4.1	3.8	3.1		
50.0	4.1	3.7	3.0		
55.0	4.0	3.4	2.8	2.0	
60.0	3.7	3.2	2.7	1.9	
65.0	3.5	3.1	2.6	1.8	
70.0	2.8	2.9	2.5	1.8	
75.0	1.7	2.6	2.5	1.8	
80.0		1.5	2.2	1.8	
85.0				1.6	
掛数	1	1	1	1	1
危険角度(°)	47	48	48	49	60
フック種類	12t	12t	12t	12t	12t
フック質量(t)	0.53	0.53	0.53	0.53	0.53

定格総荷重表注意事項

- 1) 定格総荷重は水平堅土上において本機の保証できる最大荷重を示しており、フックその他つり具等の質量を含んだ値です。なお、太枠の内側は、機械の強度によって定められ、下側は機械の安定度によって定められています。
- 2) 定格総荷重は、アウトリガ・サイドサポート・ブームロックを使用した状態で、アウトリガの張出幅とカウンタウエイトの装備状態により、次のように区分されます。

ブーム <重荷重> 【全周】

カウンタウエイト	80 t
アウトリガ張出幅	AA
7.4m	

*最大荷重は後方のみ

ブーム <通常伸縮> 【全周】

カウンタウエイト	80 t
アウトリガ張出幅	A1
9.4m	

スーパーラフingジブ 【全周】

カウンタウエイト	80 t
アウトリガ張出幅	SA
9.4m	

ヘビーリフトジブ 【全周】

カウンタウエイト	80 t
アウトリガ張出幅	HA
9.4m	

- 3) 定格総荷重のブーム角度は、ブームと水平面のなす角度を示し、ジブ角度はブームとジブのなす角度を示します。
- 4) 作業半径は、ブームのたわみを含んだ実際値に基づいていますので必ず作業半径を基準として作業を行ってください。但しスーパーラフingジブの作業半径は、40.9m ブーム・45.5m ブーム・50.0m ブームにスーパーラフingジブを装着してジブ作業を行った時の値を示し、これより短いブーム長さでのジブ作業はジブを 40.9m ブームに取り付けた時のブーム角度だけを基準として行ってください。
- 5) ブーム長さ・ブーム角度・作業半径・ジブ角度が規定の値を超えた場合は、その規定の値と次の規定の値の定格総荷重のうち小さい方の定格総荷重に従って作業を行ってください。
- 6) 定格総荷重表の危険角度は、それ以下にブームを下げると無負荷でもクレーンが転倒したり、機械の破損につながる角度を示します。
- 7) スーパーラフingジブを装着したままでブーム作業(通常伸縮)を行う場合は、ブームの定格総荷重表よりつり具の質量の他にブーム長さに応じて下表の荷重を差し引いてください。なお、スーパーラフingジブを装着したままでのブーム作業は、ブーム状態が通常伸縮時に限ります。

ブーム長さ	13.6m	18.15m	22.7m	31.8m	40.9m	45.5m	50.0m
差引荷重	25t			18t			

- 8) ルースターブの定格総荷重は、ブーム定格総荷重と等しく、かつ、限度を 12tonとします。但し、ブームにつり具等が取り付けられている場合には、定格総荷重よりつり具の質量の他にブームに取り付けられているつり具等の質量も差し引いてください。
- 9) ヘビーリフトジブ 31mの単索時定格総荷重は、ヘビーリフトジブ 31mの定格総荷重と等しく、かつ、限度を 12tonとします。
- 10) ヘビーリフトジブの起伏用ロープは、6本掛にしてください。

11) 作業状態別標準フックの種類・掛数・質量を次に示します。

なお、下表 12tonフック使用にあたり、ヘビーリフトジブ作業時にはサブウエイト有(530kg)ブーム作業(ルースタシーブ)・スーパーラフィングジブ作業時にはサブウエイト無(420kg)のフックを使用してください。

フック種類	300t	150t	83t	24t	12t	
フック質量	3720kg	1860kg	1000kg	880kg	サブウエイト無/有	
					420kg	530kg

ブーム【通常伸縮】

ブーム長さ	13.6m重荷重	13.6m	18.15m	22.7m	31.8m	40.9m	45.5m	50.0m
フック種類	300t	150t	150t	150t	83t	83t	83t	83t
掛数	28	14	12	12	7	6	4	4

ルースタシーブ

フック種類	12t
掛数	1

スーパーラフィングジブ

SL長さ	10.0m	15.0m	19.0m	23.0m	27.0m	31.0m
フック種類	24t	12t	12t	12t	12t	12t
掛数	2	1	1	1	1	1

ヘビーリフトジブ

ブーム長さ	HL長さ	13.0m	22.0m	31.0m	40.0m	47.0m	54.0m
13.6m	フック種類	150t	83t	83t (12t)	12t	12t	12t
	掛数	8	6	4 (1)	1	1	1
18.15m	フック種類	150t	83t	83t (12t)	12t	12t	12t
	掛数	8	6	4 (1)	1	1	1
22.7m	フック種類	83t	83t	83t (12t)	12t	12t	12t
	掛数	6	4	4 (1)	1	1	1
31.8m	フック種類	83t	83t	24t (12t)	12t	12t	12t
	掛数	4	4	2 (1)	1	1	1
40.9m	フック種類	—	24t	24t (12t)	12t	12t	12t
	掛数	—	2	2 (1)	1	1	1
45.5m	フック種類	—	24t	24t (12t)	12t	12t	12t
	掛数	—	2	2 (1)	1	1	1
50.0m	フック種類	—	24t	24t (12t)	12t	12t	12t
	掛数	—	2	2 (1)	1	1	1

12) 定格総荷重表は、風による影響を含んでいません。瞬間風速が 10m/secを越える場合は作業を中止してください。

13) 定格総荷重表以外の仕事を行った場合及び正しい使い方をしなかった時は、転倒又は破損します。この場合は、本機の保証はいたしません。

14) 本仕様は改良等により予告なく変更する事があります

KA-3000 重荷重吊り上げ装置付 作業範囲図

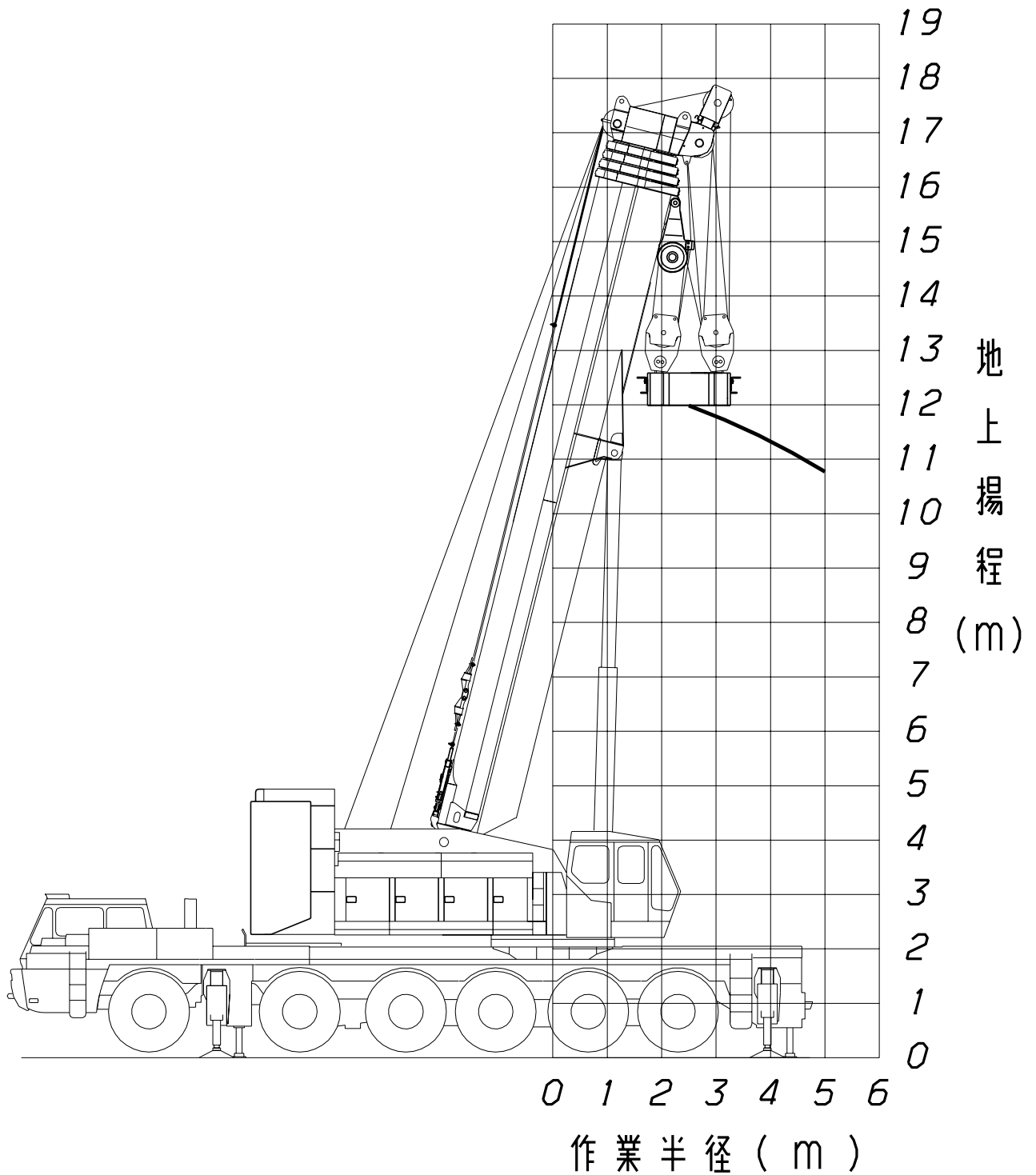

注)本図は、フレームのたわみを含んでいません。

KA-3000 フーム・ルースターシーフ 作業範囲図 <通常伸縮>

- Ⓐ 13.6m フーム
- Ⓑ 18.15m フーム
- Ⓒ 22.7m フーム
- Ⓓ 31.8m フーム
- Ⓔ 40.9m フーム
- Ⓕ 45.5m フーム
- Ⓖ 50.0m フーム
- Ⓗ 13.6m フーム+ルースターシーフ
- Ⓘ 18.15m フーム+ルースターシーフ
- Ⓝ 22.7m フーム+ルースターシーフ
- Ⓚ 31.8m フーム+ルースターシーフ
- Ⓛ 40.9m フーム+ルースターシーフ
- Ⓜ 45.5m フーム+ルースターシーフ
- Ⓝ 50.0m フーム+ルースターシーフ

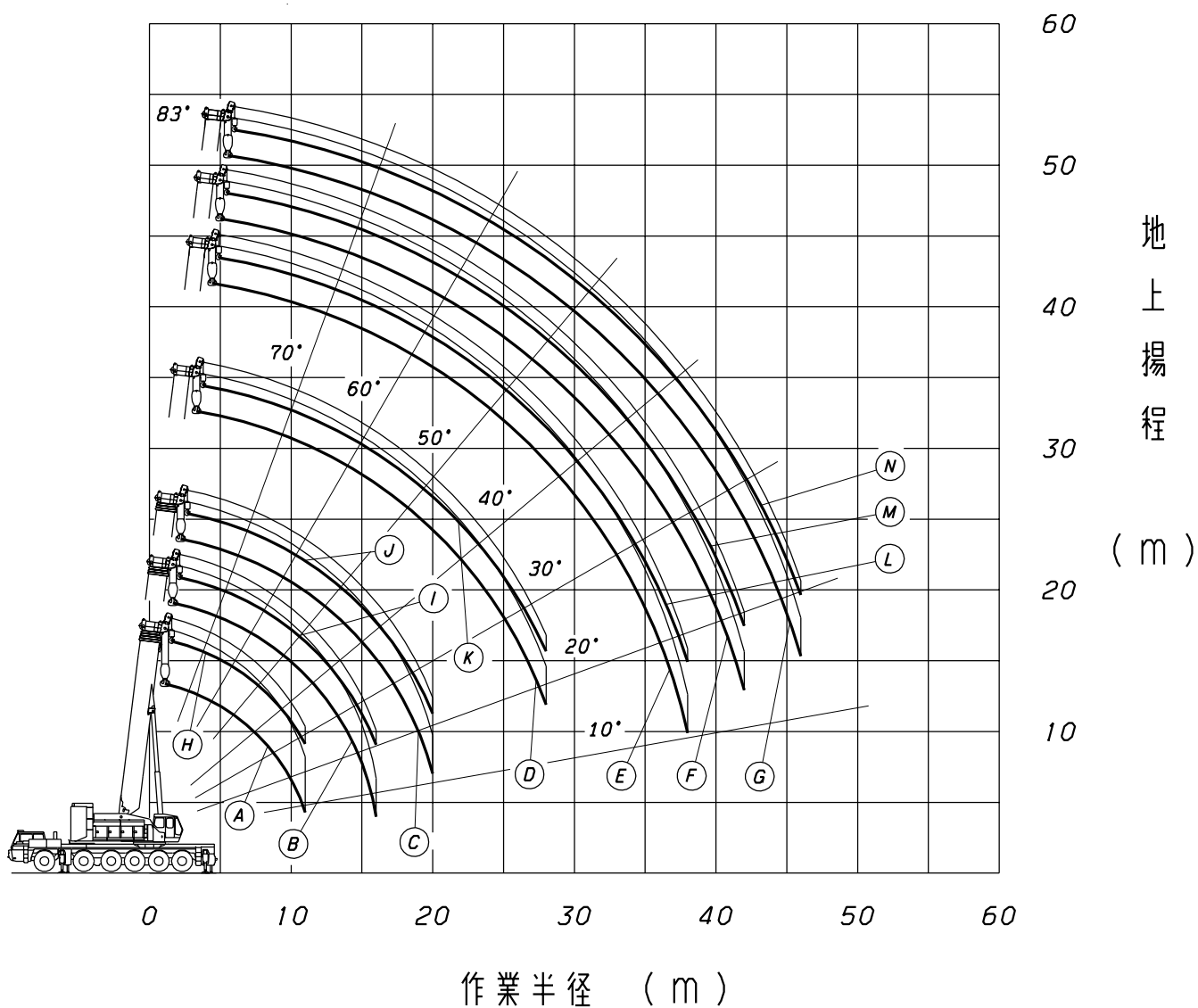

注) 本図は、フームのたわみを含んでいません。

KA-3000 S. Lジブ 作業範囲図 <50mブーム時>

(A)	50.0m	ブーム+2.0m+10.0m	S. Lジブ(オフセット 5°)
(B)	+15.0m	S. Lジブ(オフセット 5°)	
(C)	+19.0m	S. Lジブ(オフセット 5°)	
(D)	+23.0m	S. Lジブ(オフセット 5°)	
(E)	+27.0m	S. Lジブ(オフセット 5°)	
(F)	+31.0m	S. Lジブ(オフセット 5°)	
(G)	+10.0m	S. Lジブ(オフセット 60°)	
(H)	+15.0m	S. Lジブ(オフセット 60°)	
(I)	+19.0m	S. Lジブ(オフセット 60°)	
(J)	+23.0m	S. Lジブ(オフセット 60°)	
(K)	+27.0m	S. Lジブ(オフセット 60°)	
(L)	+31.0m	S. Lジブ(オフセット 60°)	

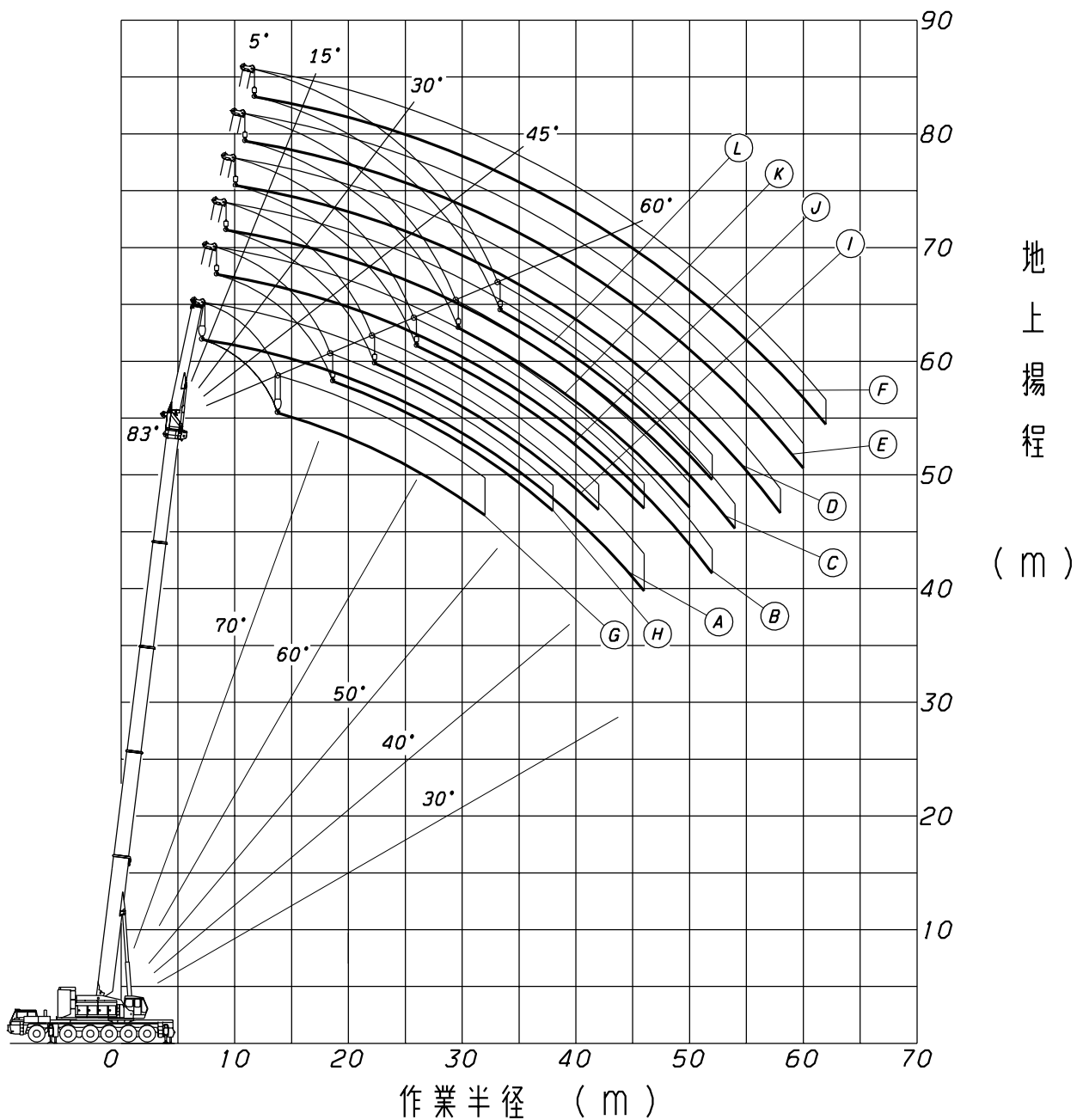

注)本図は、ブーム及びS. Lジブのたわみを含んでいません。

KA-3000 H. Lジブ 作業範囲図 <13.6m・50mブーム時>

- | | |
|---------------------------------------|---------------------------------------|
| Ⓐ 13.6mブーム+4.4m+13mヘビ-リフトジブ(オフセット10°) | Ⓜ 50.0mブーム+4.4m+22mヘビ-リフトジブ(オフセット10°) |
| Ⓑ +22mヘビ-リフトジブ(オフセット10°) | Ⓝ +31mヘビ-リフトジブ(オフセット10°) |
| Ⓒ +31mヘビ-リフトジブ(オフセット10°) | Ⓞ +40mヘビ-リフトジブ(オフセット10°) |
| Ⓓ +40mヘビ-リフトジブ(オフセット10°) | Ⓟ +47mヘビ-リフトジブ(オフセット10°) |
| Ⓔ +47mヘビ-リフトジブ(オフセット10°) | Ⓠ +54mヘビ-リフトジブ(オフセット10°) |
| Ⓕ +54mヘビ-リフトジブ(オフセット10°) | Ⓡ +22mヘビ-リフトジブ(オフセット60°) |
| Ⓖ +13mヘビ-リフトジブ(オフセット60°) | Ⓢ +31mヘビ-リフトジブ(オフセット60°) |
| Ⓗ +22mヘビ-リフトジブ(オフセット60°) | Ⓣ +40mヘビ-リフトジブ(オフセット60°) |
| Ⓘ +31mヘビ-リフトジブ(オフセット60°) | Ⓤ +47mヘビ-リフトジブ(オフセット60°) |
| Ⓚ +40mヘビ-リフトジブ(オフセット60°) | Ⓥ +54mヘビ-リフトジブ(オフセット45°) |
| Ⓛ +47mヘビ-リフトジブ(オフセット60°) | |
| Ⓩ +54mヘビ-リフトジブ(オフセット60°) | |

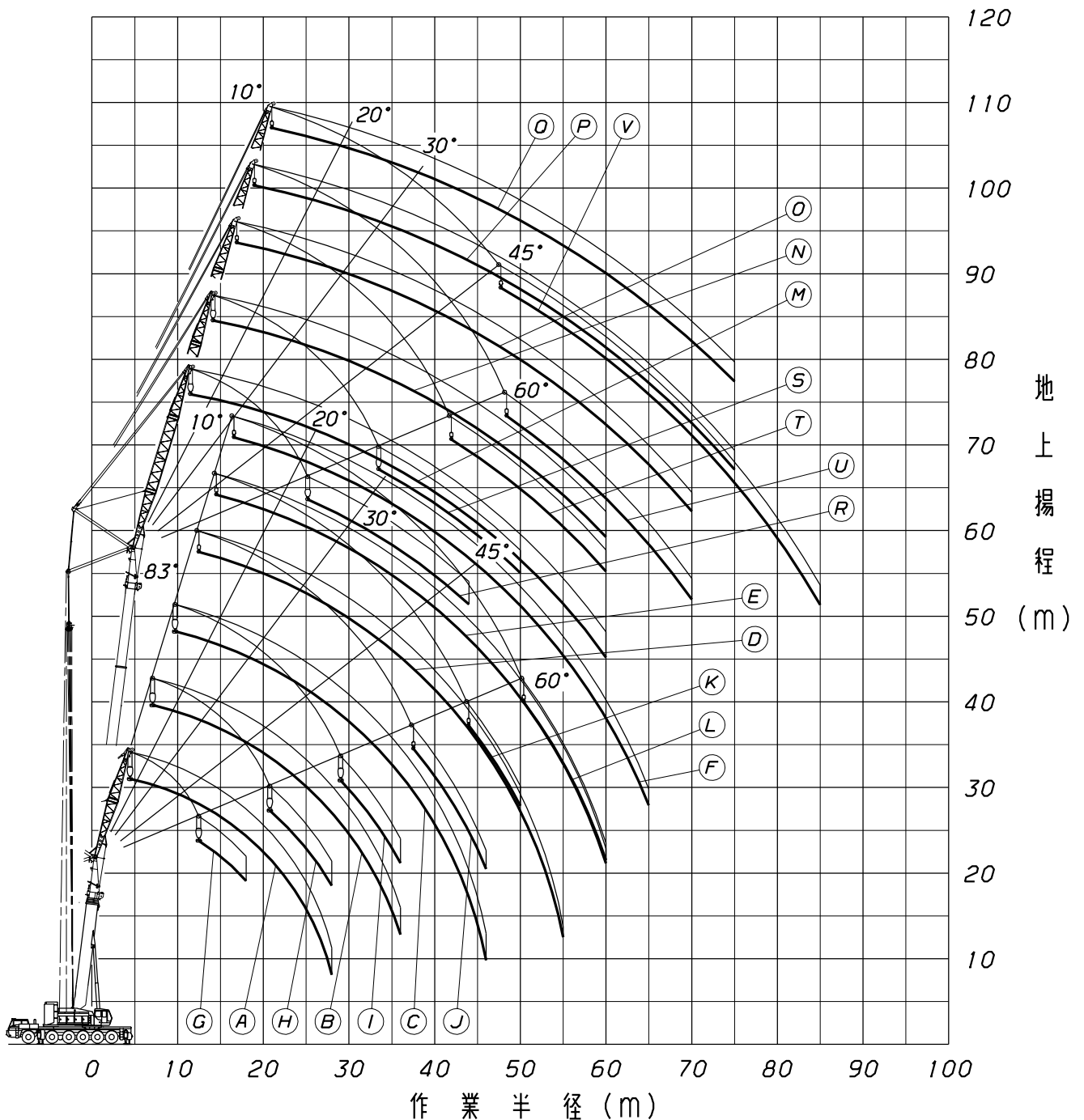

注)本図は、ブームおよびヘビ-リフトジブのたわみを含んでいません。

公道走行姿勢図

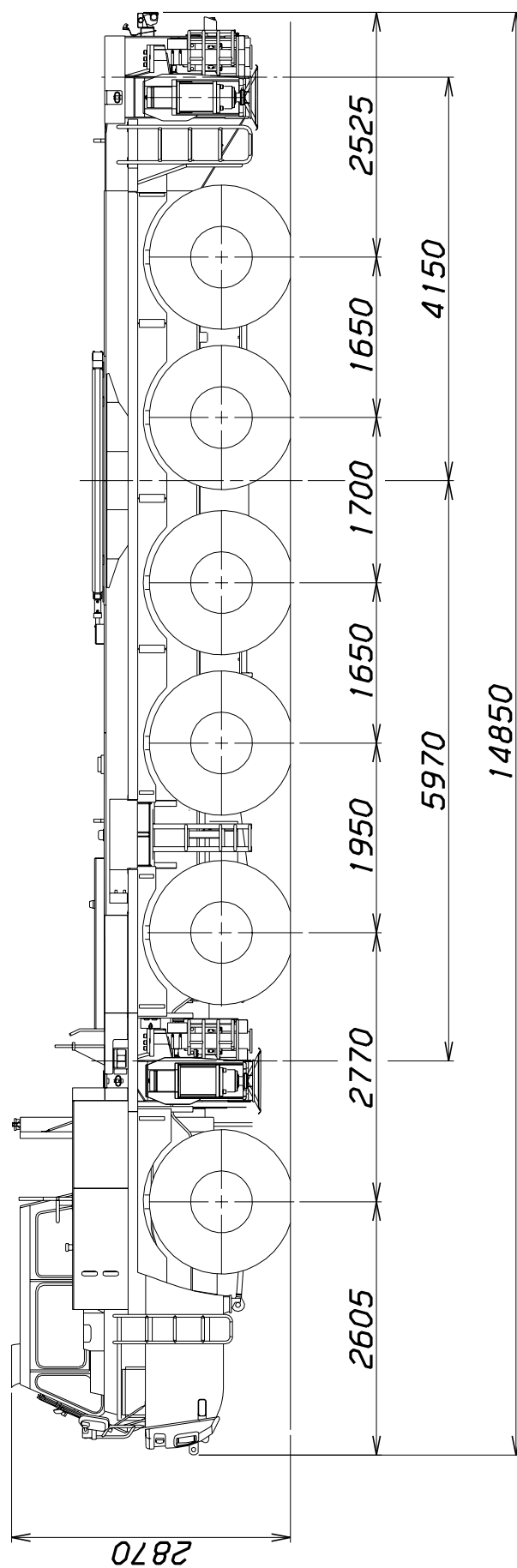
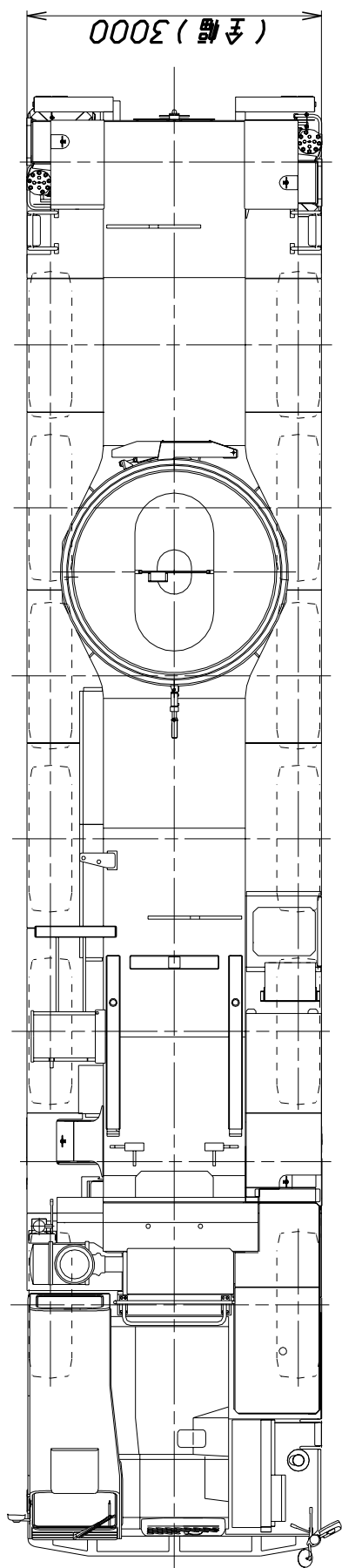

構内走行姿勢図

